



Intel[®] 845 Chipset: 82845 Memory Controller Hub (MCH) for SDR

Datasheet

January 2002

Document Number: 290725-002



Information in this document is provided in connection with Intel® products. No license, express or implied, by estoppel or otherwise, to any intellectual property rights is granted by this document. Except as provided in Intel's Terms and Conditions of Sale for such products, Intel assumes no liability whatsoever, and Intel disclaims any express or implied warranty, relating to sale and/or use of Intel products including liability or warranties relating to fitness for a particular purpose, merchantability, or infringement of any patent, copyright or other intellectual property right. Intel products are not intended for use in medical, life saving, or life sustaining applications.

Intel may make changes to specifications and product descriptions at any time, without notice.

Designers must not rely on the absence or characteristics of any features or instructions marked "reserved" or "undefined." Intel reserves these for future definition and shall have no responsibility whatsoever for conflicts or incompatibilities arising from future changes to them.

The Intel® 845 chipset may contain design defects or errors known as errata which may cause the product to deviate from published specifications. Current characterized errata are available on request.

Contact your local Intel sales office or your distributor to obtain the latest specifications and before placing your product order.

I²C is a two-wire communications bus/protocol developed by Philips. SMBus is a subset of the I²C bus/protocol and was developed by Intel. Implementations of the I²C bus/protocol may require licenses from various entities, including Philips Electronics N.V. and North American Philips Corporation.

Copies of documents which have an ordering number and are referenced in this document, or other Intel literature, may be obtained from:

Intel Corporation
www.intel.com
or call 1-800-548-4725

Intel, Pentium and the Intel logo are trademarks or registered trademarks of Intel Corporation or its subsidiaries in the United States and other countries.

*Other names and brands may be claimed as the property of others.

Copyright © 2001–2002, Intel Corporation



Contents

1	Introduction	11
1.1	Terminology and Notations	11
1.2	Reference Documents	13
1.3	Intel® 845 Chipset System Architecture	14
1.4	Intel® 82845 MCH Overview	14
1.4.1	System Bus Interface	15
1.4.2	System Bus Error Checking	15
1.4.3	System Memory Interface	16
1.4.4	AGP Interface	16
1.4.5	Hub Interface	17
1.4.6	Intel® MCH Clocking	17
1.4.7	System Interrupts	18
1.4.8	Powerdown Flow	18
2	Signal Description	19
2.1	System Bus Signals	21
2.2	SDR SDRAM Interface Signals	23
2.3	Hub Interface Signals	23
2.4	AGP Interface Signals	24
2.4.1	AGP Addressing Signals	24
2.4.2	AGP Flow Control Signals	25
2.4.3	AGP Status Signals	25
2.4.4	AGP Strokes Signals	26
2.4.5	AGP/PCI Signals	26
2.5	Clocks, Reset, and Miscellaneous Signals	28
2.6	Voltage Reference and Power Signals	29
2.7	Reset States During Reset	30
3	Register Description	31
3.1	Register Terminology	31
3.2	PCI Bus Configuration Space Access	32
3.2.1	Standard PCI Bus Configuration Mechanism	33
3.2.2	Routing Configuration Accesses	33
3.3	I/O Mapped Registers	34
3.3.1	CONF_ADDR—Configuration Address Register	34
3.3.2	CONF_DATA—Configuration Data Register	36
3.4	Memory-Mapped Register Space	36
3.4.1	DRAMWIDTH—DRAM Width Register	37
3.4.2	DQCMDSTR—Strength Control Register (SDQ and CMD Signal Groups)	38
3.4.3	CKESTR—Strength Control Register (SCKE Signal Group)	39
3.4.4	CSBSTR—Strength Control Register (SCS# Signal Group)	40
3.4.5	CKSTR—Strength Control Register (Clock Signal Group)	41
3.4.6	RCVENSTR—Strength Control Register (RCVENOUT Signal Group)	42

3.5	Host-Hub Interface Bridge Device Registers (Device 0).....	43
3.5.1	VID—Vendor Identification Register (Device 0)	45
3.5.2	DID—Device Identification Register (Device 0).....	45
3.5.3	PCICMD—PCI Command Register (Device 0)	46
3.5.4	PCISTS—PCI Status Register (Device 0).....	47
3.5.5	RID—Revision Identification Register (Device 0).....	48
3.5.6	SUBC—Sub-Class Code Register (Device 0).....	48
3.5.7	BCC—Base Class Code Register (Device 0).....	48
3.5.8	MLT—Master Latency Timer Register (Device 0).....	49
3.5.9	HDR—Header Type Register (Device 0)	49
3.5.10	APBASE—Aperture Base Configuration Register (Device 0)	50
3.5.11	SVID—Subsystem Vendor Identification (Device 0)	51
3.5.12	SID—Subsystem Identification (Device 0)	51
3.5.13	CAPPTR—Capabilities Pointer (Device 0).....	51
3.5.14	AGPM—AGP Miscellaneous Configuration Register (Device 0).....	52
3.5.15	DRB[0:7]—DRAM Row Boundary Registers (Device 0).....	52
3.5.16	DRA—DRAM Row Attribute Registers (Device 0)	53
3.5.17	DRT—DRAM Timing Register (Device 0)	55
3.5.18	DRC—DRAM Controller Mode Register (Device 0)	56
3.5.19	DERRSYN—DRAM Error Syndrome Register (Device 0)	58
3.5.20	EAP—Error Address Pointer Register (Device 0)	58
3.5.21	PAM[0:6]—Programmable Attribute Map Registers (Device 0)	59
3.5.22	FDHC—Fixed DRAM Hole Control Register (Device 0).....	62
3.5.23	SMRAM—System Management RAM Control Register (Device 0)	63
3.5.24	ESMRAMC—Extended System Mgmt RAM Control Register (Device 0).....	64
3.5.25	ACAPID—AGP Capability Identifier Register (Device 0).....	65
3.5.26	AGPSTAT—AGP Status Register (Device 0)	66
3.5.27	AGPCMD—AGP Command Register (Device 0).....	67
3.5.28	AGPCTRL—AGP Control Register (Device 0).....	68
3.5.29	APSIZE—Aperture Size (Device 0)	69
3.5.30	ATTBASE—Aperture Translation Table Base Register (Device 0).....	70
3.5.31	AMTT—AGP Interface Multi-Transaction Timer Register (Device 0) ...	71
3.5.32	LPTT—AGP Low Priority Transaction Timer Register (Device 0).....	72
3.5.33	TOM—Top of Low Memory Register (Device 0)	73
3.5.34	MCHCFG—MCH Configuration Register (Device 0).....	74
3.5.35	ERRSTS—Error Status Register (Device 0)	75
3.5.36	ERRCMD—Error Command Register (Device 0)	76
3.5.37	SMICMD—SMI Command Register (Device 0)	78
3.5.38	SCICMD—SCI Command Register (Device 0)	78
3.5.39	SKPD—Scratchpad Data Register (Device 0)	79
3.5.40	CAPID—Product Specific Capability Identifier Register (Device 0)	79
3.6	Bridge Registers (Device 1)	80
3.6.1	VID1—Vendor Identification Register (Device 1)	81
3.6.2	DID1—Device Identification Register (Device 1).....	81
3.6.3	PCICMD1—PCI-PCI Command Register (Device 1).....	82
3.6.4	PCISTS1—PCI-PCI Status Register (Device 1).....	83
3.6.5	RID1—Revision Identification Register (Device 1).....	84
3.6.6	SUBC1—Sub-Class Code Register (Device 1).....	84
3.6.7	BCC1—Base Class Code Register (Device 1).....	84
3.6.8	MLT1—Master Latency Timer Register (Device 1).....	85
3.6.9	HDR1—Header Type Register (Device 1)	85
3.6.10	PBUSN1—Primary Bus Number Register (Device 1)	85



3.6.11	SBUSN1—Secondary Bus Number Register (Device 1)	86
3.6.12	SUBUSN1—Subordinate Bus Number Register (Device 1).....	86
3.6.13	SMLT1—Secondary Master Latency Timer Register (Device 1)	87
3.6.14	IOBASE1—I/O Base Address Register (Device 1)	88
3.6.15	IOLIMIT1—I/O Limit Address Register (Device 1)	88
3.6.16	SSTS1—Secondary PCI-PCI Status Register (Device 1)	89
3.6.17	MBASE1—Memory Base Address Register (Device 1).....	90
3.6.18	MLIMIT1—Memory Limit Address Register (Device 1).....	90
3.6.19	PMBASE1—Prefetchable Memory Base Address Register (Device 1).....	91
3.6.20	PMLIMIT1—Prefetchable Memory Limit Address Register (Device 1).....	91
3.6.21	BCTRL1—PCI-PCI Bridge Control Register (Device 1).....	92
3.6.22	ERRCMD1—Error Command Register (Device 1)	93
3.6.23	DWTC—DRAM Write Thermal Management Control Register (Device 1).....	94
3.6.24	DRTC—DRAM Read Thermal Management Control Register (Device 1).....	95
4	System Address Map.....	97
4.1	Memory Address Ranges	97
4.1.1	VGA and MDA Memory Space.....	99
4.1.2	PAM Memory Spaces.....	100
4.1.3	ISA Hole Memory Space	100
4.1.4	TSEG SMM Memory Space	101
4.1.5	IOAPIC Memory Space	101
4.1.6	System Bus Interrupt APIC Memory Space	101
4.1.7	High SMM Memory Space.....	101
4.1.8	AGP Aperture Space (Device 0 BAR)	102
4.1.9	AGP Memory and Prefetchable Memory.....	102
4.1.10	Hub Interface Subtractive Decode	102
4.2	AGP Memory Address Ranges.....	102
4.2.1	AGP DRAM Graphics Aperture	103
4.3	System Management Mode (SMM) Memory Range.....	103
4.3.1	SMM Space Definition	104
4.3.2	SMM Space Restrictions	104
4.4	I/O Address Space.....	105
4.5	Intel® MCH Decode Rules and Cross-Bridge Address Mapping.....	105
4.5.1	Hub Interface Decode Rules	105
4.5.2	AGP Interface Decode Rules	106
5	Functional Description	107
5.1	System Bus.....	107
5.1.1	Dynamic Bus Inversion.....	107
5.1.2	System Bus Interrupt Delivery.....	108
5.1.3	Upstream Interrupt Messages.....	108
5.2	System Memory Interface	109
5.2.1	Single Data Rate (SDR) SDRAM Interface Overview	109
5.2.2	Memory Organization and Configuration.....	109
5.2.2.1	Configuration Mechanism For DIMMs	110
5.2.3	Memory Address Translation and Decoding	111
5.2.4	DRAM Performance Description	112
5.2.4.1	Data Integrity (ECC).....	112



5.3	AGP Interface Overview	112
5.3.1	AGP Target Operations.....	112
5.3.2	AGP Transaction Ordering.....	114
5.3.3	AGP Signal Levels.....	114
5.3.4	4x AGP Protocol.....	114
5.3.5	Fast Writes	114
5.3.6	AGP FRAME# Transactions on AGP.....	115
5.4	Power and Thermal Management	117
5.4.1	Processor Power State Control.....	117
5.4.2	Sleep State Control	118
5.5	Intel® MCH Clocking	118
5.6	Intel® MCH System Reset and Power Sequencing.....	118
6	Electrical Characteristics	119
6.1	Absolute Maximum Ratings	119
6.2	Power Characteristics	119
6.3	Signal Groups	120
6.4	DC Characteristics	122
7	Ballout and Package Information.....	125
7.1	Package Mechanical Information.....	134
8	Testability.....	137
8.1	XOR Test Mode Initialization	137
8.2	XOR Chains	138



Figures

Figure 1. Intel® MCH Simplified Block Diagram.....	20
Figure 2. PAM Register Attributes	60
Figure 3. Addressable Memory Space	97
Figure 4. DOS Compatible Area Address Map.....	98
Figure 5. Extended Memory Range Address Map	98
Figure 6. Intel® 82845 MCH Ballout Diagram (Top View—Left Side).....	126
Figure 7. Intel® 82845 MCH Ballout Diagram (Top View—Right Side).....	127
Figure 8. Intel® MCH FC-BGA Package Dimensions (Top and Side View).....	134
Figure 9. Intel® MCH FC-BGA Package Dimensions (Bottom View).....	135
Figure 10. XOR Tree Chain.....	137

Tables

Table 1. General Terminology	11
Table 2. Data Type Notation	12
Table 3. Number Format Notation	12
Table 4. Memory Capacity	16
Table 5. Intel® MCH Clock Ratio Table	17
Table 6. Intel® MCH Internal Device Assignments	32
Table 7. Memory-mapped Register Address Map.....	36
Table 8. Intel® MCH Configuration Space (Device 0)	43
Table 9. PAM Register Attributes	61
Table 10. Intel® MCH Configuration Space (Device 1)	80
Table 11. SMM Space Address Ranges	104
Table 12. Supported DIMM Configurations	109
Table 13. Data Bytes on DIMM Used for Programming DRAM Registers	110
Table 14. Address Translation and Decoding	111
Table 15. AGP Commands Supported by the Intel® MCH When Acting as an AGP Target	113
Table 16. Data Rate Control Bits.....	115
Table 17. PCI Commands Supported by the Intel® MCH (When Acting as a FRAME# Target)	115
Table 18. Absolute Maximum Ratings.....	119
Table 19. Power Characteristics.....	119
Table 20. Signal Groups.....	120
Table 21. DC Characteristics.....	122
Table 22. Intel® 82845 MCH Ballout Listed Alphabetically by Signal Name	128
Table 23. XOR Chain 0	138
Table 24. XOR Chain 1	140
Table 25. XOR Chain 2	141
Table 26. XOR Chain 3	142
Table 27. XOR Chain 4	143
Table 28. XOR Chain 5	144
Table 29. XOR Chain 6	146
Table 30. XOR Chain 7	147

Revision History

Revision Number	Description	Date
-001	Initial Release.	September 2001
-002	<ul style="list-style-type: none">• Changed the document name to add the term “for SDR”.• DWTC—DRAM Write Thermal Management Control Register was incorrectly placed in Device 0. It should be in Device 1.• DRTC—DRAM Read Thermal Management Control Register was incorrectly placed in Device 0. It should be in Device 1.	January 2002



Intel® 82845 MCH Features

- Intel® Pentium® 4 Processor (478 pin package) Support
 - Enhanced Mode Scaleable Bus Protocol
 - 2x Address, 4x Data
 - System Bus interrupt delivery
 - 400 MHz system bus
 - System Bus Dynamic Bus Inversion (DBI)
 - 32-bit system bus addressing
 - 12 deep In-Order Queue
 - AGTL+ bus driver technology with integrated AGTL+ termination resistors
- System Memory Support
 - Directly supports one SDR SDRAM channel, 64 bits wide (72 bits with ECC)
 - 133 MHz Single Data Rate (SDR) SDRAM devices
 - 64 Mb, 128 Mb, 256 Mb and 512 Mb technologies for x8 and x16 devices
 - By using 64 Mb technology, the smallest memory capacity possible is 32 MB
 - Configurable optional ECC operation (single bit Error Correction and multiple bit Error Detection)
 - Page sizes of 2 KB, 4 KB, 8 KB and 16 KB (individually selected for every row)
 - Thermal management
 - Maximum of 3 Double-Sided DIMMs (6 rows populated) with unbuffered PC133 (with or without ECC)
Note: Mixed mode, populating ECC and Non-ECC Memories simultaneously is not supported.
 - 3 GB Maximum using 512 Mb technology
 - Supports up to 24 simultaneous open pages
 - Maximum memory bandwidth of 1.067 GB/s with PC133
- Hub Interface to Intel® 82801BA ICH2
 - 266 MB/s point-to-point hub interface to ICH2
 - 66 MHz base clock
 - MSI interrupt messages, power management state change, SMI, SCI and SERR error indication
- Accelerated Graphics Port (AGP) Interface
 - Supports a single AGP device (either a connector or on the motherboard)
 - Supports AGP 2.0 including 1x, 2x, and 4x AGP data transfers and 2x/4x Fast Write protocol
 - Supports only 1.5 V AGP electrical characteristics
 - 32 deep AGP request queue
 - Delayed transaction support for AGP-to-System Memory FRAME# semantic reads
- System Interrupt Support
 - System bus interrupt delivery mechanism
 - Interrupts signaled as upstream memory writes from AGP/PCI
 - Supports peer MSI between hub interface and AGP
 - Provides redirection for IPI and upstream interrupts to the system bus
- Power Management
 - SMRAM space remapping to A0000h
 - Supports extended SMRAM space above 256 MB, additional TSEG from Top of Memory
 - SMRAM accesses from AGP or hub interface are not supported
 - PC '99 suspend to DRAM support
 - ACPI, Revision 1.0b compliant power management
 - APM, Revision 1.2 compliant power management
 - NT Hardware Design Guide, Version 1.0 compliant
- Package
 - MCH: 593 pin FC-BGA (37.5 x 37.5 mm)

System Block Diagram

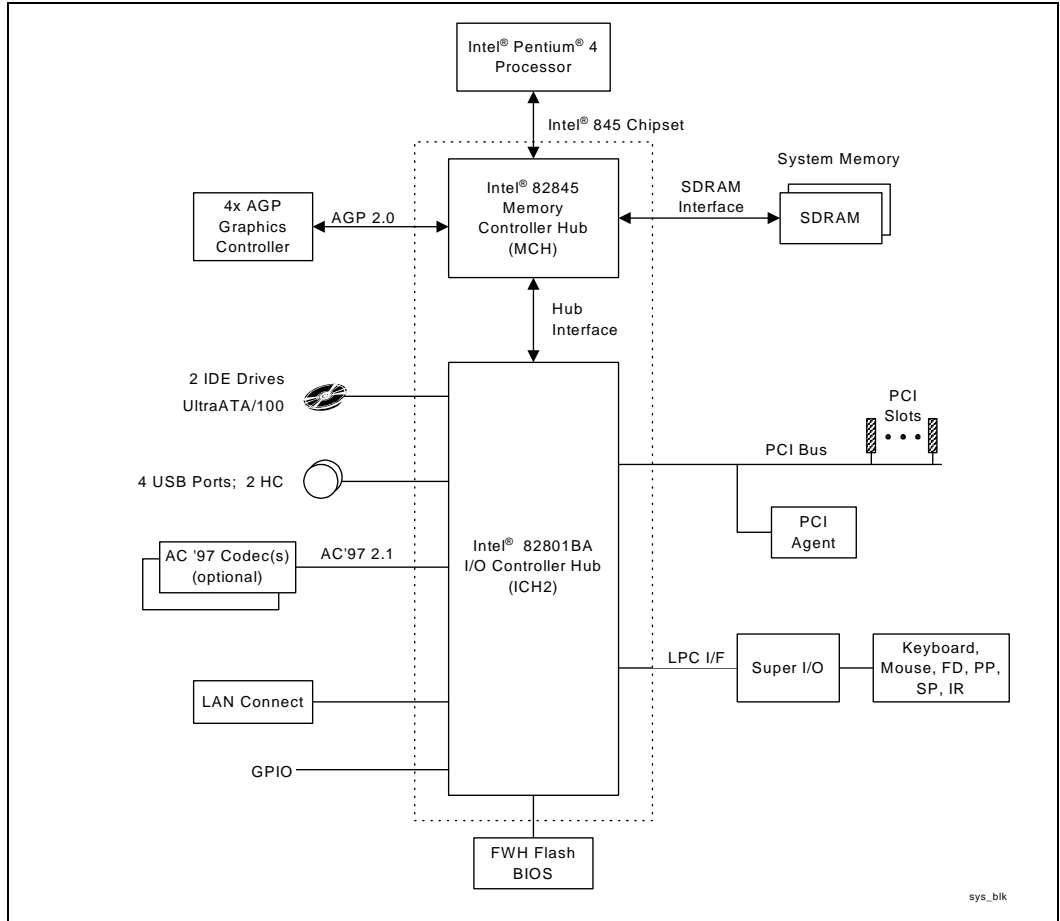

1 Introduction

The Intel® 82845 Memory Controller Hub (MCH) is designed for use with the Intel® Pentium® 4 processor in the 478-pin package. The Intel® 845 chipset contains two main components: the 82845 Memory Controller Hub (MCH) for the host bridge and the Intel 82801BA I/O Controller Hub (ICH2) for the I/O subsystem. The MCH provides the processor interface, system memory interface, AGP interface, and hub interface in an 845 chipset desktop platform.

This document describes the 82845 Memory Controller Hub (MCH) for use with SDR (Single Data Rate) memory devices. Section 1.3 provides an overview of the 845 chipset.

1.1 Terminology and Notations

This section provides the definitions of some of the terms used in this document. Notations used for data types and numbers are also included. In addition, Section 3.1 contains register terminology definitions.

Table 1. General Terminology

Term	Description
MCH	The Memory Controller Hub component that contains the processor interface, System Memory DRAM controller, and AGP interface. It communicates with the I/O controller hub (ICH2) and other IO controller hubs over proprietary interconnect called the hub interface.
ICH2	The I/O Controller Hub component that contains the primary PCI interface, LPC interface, USB, ATA-100, AC '97, and other I/O functions. It communicates with the MCH over a proprietary interconnect called the hub interface.
Host	This term is used synonymously with processor.
Core	The internal base logic in the MCH.
System Bus	Processor-to-MCH interface. The system bus runs at 400 MHz, from a 100 MHz quad-pumped clock. It consists of source synchronous transfers for address and data, and system bus interrupt delivery.
Hub Interface	The proprietary hub interconnect that connects the MCH to the ICH2. In this document hub interface cycles originating from or destined for the primary PCI interface on the ICH2 are generally referred to as hub interface cycles.
Accelerated Graphics Port (AGP)	Refers to the AGP interface that is in the MCH. The MCH supports AGP 2.0 compliant components only with 1.5 V signaling level. PIPE# and SBA addressing cycles and their associated data phases are generally referred to as AGP transactions. FRAME# cycles over the AGP bus are generally referred to as AGP/PCI transactions.
PCI_A	The physical PCI bus, driven directly by the ICH2 component. It supports 5 V, 32-bit, 33 MHz PCI 2.2 compliant components. Communication between PCI_A and the MCH occurs over the hub interface. Note: Even though this PCI bus is referred to as PCI_A, it is not PCI Bus #0 from a configuration standpoint.
Full Reset	A full MCH reset is defined in this document when RSTIN# is asserted.

Term	Description
GART	Graphics Aperture Re-map Table. This table contains the page re-map information used during AGP aperture address translations.
GTLB	Graphics Translation Look-aside Buffer. A cache used to store frequently used GART entries.
UP	Uni-Processor.
DBI	Dynamic Bus inversion.
MSI	Message Signaled Interrupts. MSIs allow a device to request interrupt service via a standard memory write transaction instead of through a hardware signal.
IPI	Inter Processor Interrupt.
SDR	Single Data-Rate SDRAM memory.

Table 2. Data Type Notation

Data Type	Size
bit (b)	Smallest unit, 0 or 1
byte	8 bits
word	16 bits = 2 bytes
DWord (DW)	Doubleword: 32 bits = 4 bytes
QWord (QW)	Quadword: 8 bytes = 4 words
DQWord (DQW)	Double Quadword. 16 bytes or 8 words. This is sometimes referred to as a Superword (SW or SWord), and is also referred to as a "Cache Line".
Kilobyte (KB)	1024 bytes
Megabit (Mb)	1,048,576 bits = 128 KB
Megabyte (MB)	1,048,576 bytes = 1024 KB
Gigabit (Gb)	1024 Mb
Gigabyte (GB)	1024 MB

Table 3. Number Format Notation

Number Format	Notation	Example
Decimal (default)		14
Binary	b	1110b
Hex	h	0Eh

1.2 Reference Documents

Document	Document Number / Location
<i>Intel® Pentium 4 Processor in a 478 Pin Package and Intel® 845 Chipset Platform for SDR Design Guide</i>	298354
<i>Intel® 82801BA I/O Controller Hub (ICH2) and Intel® 82801BAM I/O Controller Hub (ICH2-M) Datasheet</i>	290687
<i>Intel® 845 Chipset Thermal and Mechanical Design Guidelines for SDR</i>	298586
<i>Intel® 82802AB/AC Firmware Hub (FWH) Datasheet</i>	290658
<i>PCI Local Bus Specification, Revision 2.1</i>	Contact Intel Field Representative
<i>Accelerated Graphics Port Interface Specification, Revision 2.0</i>	www.agforum.org
<i>Intel® Pentium 4 Processor Datasheet</i>	
<i>PC SDRAM Specification, Rev. 1.7</i>	developer.intel.com

Note: See the *Intel® Pentium 4 Processor in a 478 Pin Package and Intel® 845 Chipset Platform Design Guide* for an expanded set of related documents.

1.3 Intel® 845 Chipset System Architecture

The MCH provides the processor interface, system memory interface, AGP interface, and hub interface in an 845 chipset desktop platform. The processor interface supports the Pentium 4 processor subset of the Extended Mode of the Scalable Bus Protocol. The MCH supports a single channel of PC133 SDRAM. The MCH contains advanced power management logic. The 845 chipset platform supports the I/O Controller Hub 2 (ICH2) to provide the features required by a desktop platform.

Intel® 82801BA I/O Controller Hub 2 (ICH2)

The ICH2 is a highly integrated multifunctional I/O Controller Hub that provides the interface to the PCI Bus and integrates many of the functions needed in today's PC platforms. The MCH and ICH2 communicate over a dedicated hub interface. The 82801BA ICH2 Functions and capabilities include:

- PCI Rev 2.2 compliant with support for 33 MHz PCI operations
- Supports up to 6 Request/Grant pairs (PCI slots)
- Power management logic support
- Enhanced DMA controller, interrupt controller, and timer functions
- Integrated IDE controller; Ultra ATA/100/66/33
- USB host interface; 2 host controllers and supports 4 USB ports
- Integrated LAN controller
- System Management Bus (SMBus) compatible with most I²C devices; ICH2 has both bus master and slave capability
- AC '97 2.1 compliant link for audio and telephony codecs; up to 6 channels (ICH2)
- Low Pin Count (LPC) interface
- FWH Interface (FWH Flash BIOS support)
- Alert on LAN* (AOL and AOL2)

1.4 Intel® 82845 MCH Overview

The MCH role in a system is to manage the flow of information between its four interfaces: the system bus, the memory interface, the AGP port, and the hub interface. The MCH arbitrates between the four interfaces, when each initiates an operation. While doing so, the MCH supports data coherency via snooping and performs address translation for access to AGP Aperture memory. To increase system performance, the MCH incorporates several queues and a write cache.

The MCH is in a 593 pin FC-BGA package and contains the following functionality:

- Supports single Pentium 4 processor configuration at 400 MHz
- AGTL+ system bus with integrated termination supporting 32-bit system bus addressing
- Up to 3 GB (w/ 512 Mb technology) of PC133 SDRAM
- 1.5 V AGP interface with 4x SBA/data transfer and 2x/4x fast write capability
- 8 bit, 66 MHz 4x hub interface to the ICH2
- Distributed arbitration for highly concurrent operation

1.4.1 System Bus Interface

The MCH is optimized for the Pentium 4 processor. The primary enhancements over the Compatible Mode P6 bus protocol are:

- Source synchronous double-pumped address
- Source synchronous quad-pumped data
- System bus interrupt and side-band signal delivery

The MCH supports a 64-byte cache line size. Only one processor is supported at a system bus frequency of 400 MHz. The MCH supports a 3:4 host-to-memory frequency ratio (using the 100 MHz clock). The MCH integrates AGTL+ termination resistors on all of the AGTL+ signals. The MCH supports 32-bit system bus addresses, allowing the processor to access the entire 4 GB of the MCH memory address space.

The MCH has a 12-deep In-Order Queue to support up to twelve outstanding pipelined address requests on the system bus. The MCH supports two outstanding defer cycles at a time; however, only one to any particular I/O interface. Processor-initiated I/O cycles are positively decoded to AGP/PCI or MCH configuration space and subtractively decoded to the hub interface. Processor-initiated memory cycles are positively decoded to AGP/PCI or system memory, and are again subtractively decoded to the hub interface, if under 4 GB. AGP semantic memory accesses initiated from AGP/PCI to system memory are not snooped on the system bus. Memory accesses initiated from AGP/PCI using PCI semantics and from the hub interface to system memory will be snooped on the system bus. Memory accesses whose addresses lie within the AGP aperture are translated using the AGP address translation table, regardless of the originating interface.

1.4.2 System Bus Error Checking

The MCH does not generate parity, nor check parity for data, address/request, and response signals on the processor bus.

1.4.3 System Memory Interface

The MCH directly supports one channel of PC133 SDRAM. The memory interface supports Single Data Rate (SDR) devices with densities of 64 Mb, 128 Mb, 256 Mb, and 512 Mb technology. The memory interface also supports variable page sizes of 2 KB, 4 KB, 8 KB, and 16 KB. Page size is individually selected for every row and a maximum of 8 pages per DIMM may be opened simultaneously.

The MCH supports a maximum of 3 double-sided DIMMs (6 rows populated) with unbuffered PC133 (with or without ECC) Note that in mixed mode, populating ECC and Non-ECC memories simultaneously is not supported.

Table 4. Memory Capacity

Technology	SDR (PC133) Maximum
64 Mb	384 MB
128 Mb	768 MB
256 Mb	1.5 GB
512 Mb	3 GB

The memory interface provides optional ECC error checking for system memory data integrity. During system memory writes, ECC is generated on a QWord (64 bit) basis. Because the MCH stores only entire cache lines in its internal buffers, partial QWord writes initially cause a read of the underlying data, and their write-back into memory is no different from that of a complete cache line. During system memory reads, and the read of the data that underlies partial writes, the MCH supports detection of single-bit and multiple-bit errors, and will correct single-bit errors when correction is enabled.

The MCH supports a thermal management scheme to selectively manage reads and/or writes. Thermal management can be triggered by preset read/write bandwidth limits.

1.4.4 AGP Interface

A single AGP component or connector (not both) is supported by the MCH AGP interface. The AGP buffers operate **only** in 1.5 V mode. They are not 3.3 V safe.

The AGP interface supports 1x/2x/4x AGP signaling and 2x/4x fast writes. AGP semantic cycles to system memory are not snooped on the system bus. PCI semantic cycles to system memory are snooped on the system bus. The MCH supports PIPE# or SBA[7:0] AGP address mechanisms, but not both simultaneously. Either the PIPE# or the SBA[7:0] mechanism must be selected during system initialization. Both upstream and downstream addressing is limited to 32 bits for AGP and AGP/PCI transactions. The MCH contains a 32 deep AGP request queue. High-priority accesses are supported. All accesses from the AGP/PCI interface that fall within the Graphics Aperture address range pass through an address translation mechanism with a fully associative 20 entry TLB. Accesses between AGP and hub interface are limited to memory writes originating from the hub interface destined for AGP. The AGP interface is clocked from a dedicated 66 MHz clock (66IN). The AGP-to-host/core interface is asynchronous.

1.4.5 Hub Interface

The 8-bit hub interface connects the MCH to the ICH2. All communication between the MCH and the ICH2 occurs over the hub interface. The hub interface runs at 66 MHz / 266 MB/s. In addition to the normal traffic types, the following communication also occurs over the hub interface:

- Interrupt related messages
- Power management events as messages
- SMI, SCI, and SERR error indication messages

It is assumed that the hub interface is always connected to an ICH2.

1.4.6 Intel® MCH Clocking

The MCH has the following clock input pins:

- Differential BCLK for the host interface
- 66 MHz clock input for the AGP and hub interface

Clock synthesizer chip(s) generate the system host clocks, AGP and hub interface clocks, and PCI clocks. The system bus target speed is 400 MHz. The MCH does not require any relationship between the HCLKIN host clock and the 66 MHz clock generated for AGP and the hub interface; they are asynchronous to each other. The AGP and hub interface runs at a constant 66 MHz base frequency. The hub interface runs at 4x. AGP transfers can be 1x, 2x, or 4x. Table 5 indicates the supported frequency ratios between the various interfaces.

Table 5. Intel® MCH Clock Ratio Table

Interface	Speed	Processor BCLK (100 MHz)
Memory	SDR 133 MHz	3:4 synchronous
AGP	66 MHz	Asynchronous
Hub interface	66 MHz	Asynchronous



1.4.7 System Interrupts

The MCH supports both Intel 8259 and Pentium 4 processor interrupt delivery mechanisms. The serial APIC interrupt mechanism is not supported.

Intel 8259 support consists of flushing inbound hub interface write buffers when an Interrupt Acknowledge cycle is forwarded from the system bus to the hub interface.

The MCH supports the Pentium 4 processor interrupt delivery mechanism. IOxAPIC and PCI MSI interrupts are generated as memory writes. The MCH decodes upstream memory writes to the range 0FEE0_0000h–0FEEF_FFFFh from AGP and the hub interface as message-based interrupts. The MCH forwards the memory writes, along with the associated write data, to the system bus as an interrupt message transaction. Note that since this address does not decode as part of system memory, the write cycle and the write data are not forwarded to system memory via the write buffer. The MCH provides the response and TRDY# for all interrupt message cycles, including the ones originating from the MCH. The MCH supports interrupt re-direction for inter-processor interrupts (IPIs) as well as upstream interrupt memory writes.

For message-based interrupts, system write-buffer coherency is maintained by relying on strict ordering of memory writes. The MCH ensures that all memory writes received from a given interface prior to an interrupt message memory write are delivered to the system bus for snooping in the same order that they occur on the given interface.

1.4.8 Powerdown Flow

Since the MCH is powered down during STR, the MCH cannot maintain any state information when exiting STR. Thus, the entire initialization process when exiting STR must be performed by the BIOS via accesses to the DRC2 register.

Entry into STR (ACPI S3) is initiated by the Operating System (OS), based on detecting a lack of system activity. The OS unloads all system device drivers as part of the process of entering STR. The OS then writes to the PM1_CNT I/O register in the ICH2 to trigger the transition into STR.

2 Signal Description

This chapter provides a detailed description of the MCH signals. The signal descriptions are arranged in functional groups according to their associated interface (see Figure 1). The states of all of the signals during reset are provided in the System Reset section.

The “#” symbol at the end of a signal name indicates that the active, or asserted state occurs when the signal is at a low voltage level. When “#” is not present after the signal name the signal is asserted when at the high voltage level.

The following notations are used to describe the signal type:

I	Input pin
O	Output pin
I/O	Bi-directional Input/Output pin
s/t/s	Sustained Three-state. This pin is driven to its inactive state prior to three-stating.
as/t/s	Active Sustained Three-state. This applies to some of the hub interface signals. This pin is weakly driven to its last driven value.

The signal description also includes the type of buffer used for the particular signal:

AGTL+	Open Drain AGTL+ interface signal. Refer to the AGTL+ I/O Specification for complete details. The MCH integrates AGTL+ termination resistors.
AGP	AGP interface signals. These signals are compatible with AGP 2.0 1.5 V Signaling Environment DC and AC Specifications. The buffers are not 3.3 V tolerant.
CMOS	CMOS buffers.
Ref	Voltage reference signal

Note: System address and data bus signals are logically inverted signals. In other words, the actual values are inverted of what appears on the system bus. This must be taken into account and the addresses and data bus signals must be inverted inside the MCH. All processor control signals follow normal convention. A “0” indicates an active level (low voltage) if the signal is followed by “#” symbol, and a “1” indicates an active level (high voltage) if the signal has no “#” suffix.

Figure 1. Intel® MCH Simplified Block Diagram

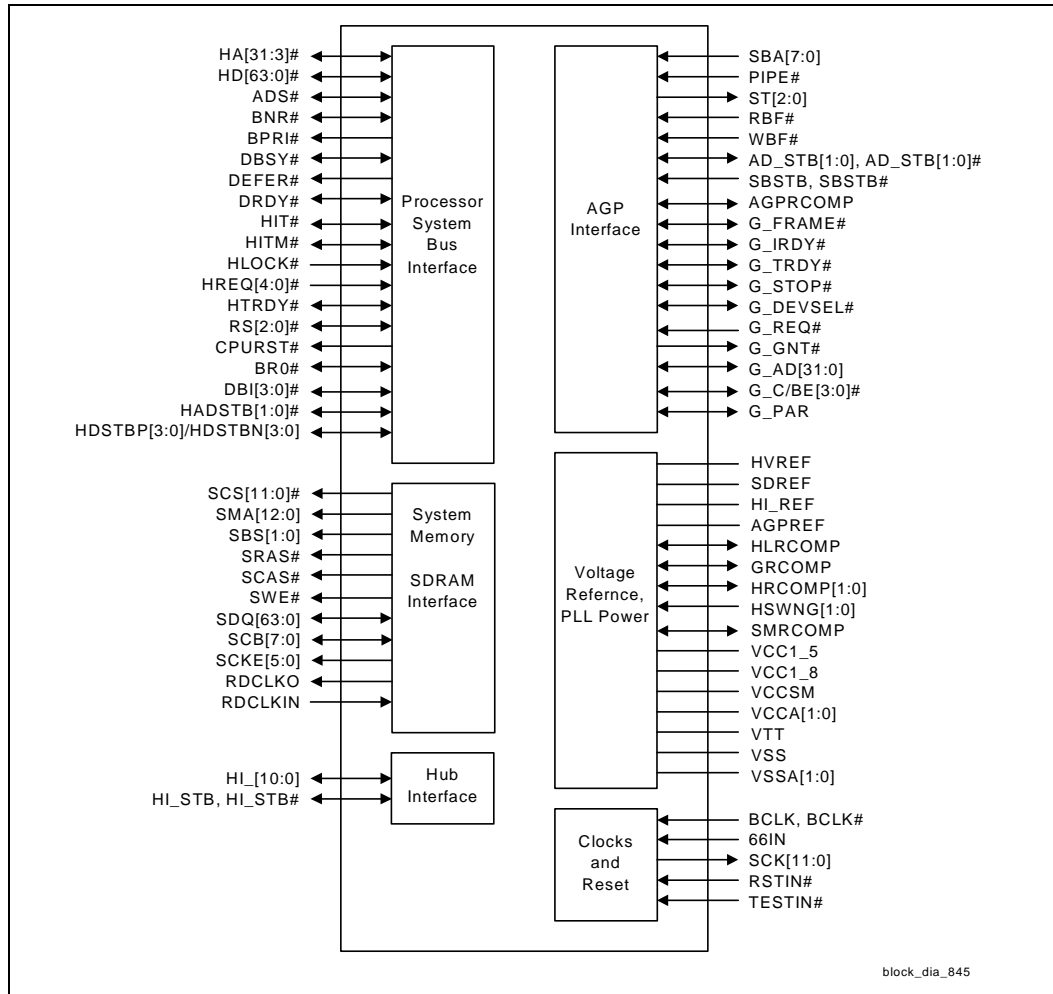

2.1 System Bus Signals

Signal Name	Type	Description										
ADS#	I/O AGTL+	Address Strobe: The system bus owner asserts ADS# to indicate the first of two cycles of a request phase.										
BNR#	I/O AGTL+	Block Next Request: BNR# is used to block the current request bus owner from issuing a new request. This signal dynamically controls the system bus pipeline depth.										
BPRI#	O AGTL+	Bus Priority Request: The MCH is the only Priority Agent on the system bus. It asserts this signal to obtain the ownership of the address bus. This signal has priority over symmetric bus requests and will cause the current symmetric owner to stop issuing new transactions unless the HLOCK# signal was asserted.										
BR0#	I/O AGTL+	Bus Request 0#: The MCH pulls the processor bus BR0# signal low during CPURST#. The signal is sampled by the processor on the active-to-inactive transition of CPURST#. The minimum setup time for this signal is 4 BCLKs. The minimum hold time is 2 BCLKs and the maximum hold time is 20 BCLKs. BR0# should be three-stated after the hold time requirement has been satisfied.										
CPURST#	O AGTL+	Processor Reset: The CPURST# pin is an output from the MCH. The MCH asserts CPURST# while RSTIN# (PCIRST# from the ICH2) is asserted and for approximately 1 ms after RSTIN# is deasserted. The CPURST# allows the processor to begin execution in a known state.										
DBSY#	I/O AGTL+	Data Bus Busy: DBSY# is used by the data bus owner to hold the data bus for transfers requiring more than one cycle.										
DEFER#	O AGTL+	Defer Response: This signal, when asserted, indicates that the MCH will terminate the transaction currently being snooped with either a deferred response or with a retry response.										
DBI[3:0]#	I/O AGTL+	<p>Dynamic Bus Inversion: DBI[3:0]# are driven along with the HD[63:0]# signals. DBI[3:0]# indicate if the associated data signals are inverted. DBI[3:0]# are asserted such that the number of data bits driven electrically low (low voltage) within the corresponding 16-bit group never exceeds 8.</p> <table border="0"> <thead> <tr> <th>DBI[x]#</th> <th>Data Bits</th> </tr> </thead> <tbody> <tr> <td>DBI3#</td> <td>HD[63:48]#</td> </tr> <tr> <td>DBI2#</td> <td>HD[47:32]#</td> </tr> <tr> <td>DBI1#</td> <td>HD[31:16]#</td> </tr> <tr> <td>DBI0#</td> <td>HD[15:0]#</td> </tr> </tbody> </table>	DBI[x]#	Data Bits	DBI3#	HD[63:48]#	DBI2#	HD[47:32]#	DBI1#	HD[31:16]#	DBI0#	HD[15:0]#
DBI[x]#	Data Bits											
DBI3#	HD[63:48]#											
DBI2#	HD[47:32]#											
DBI1#	HD[31:16]#											
DBI0#	HD[15:0]#											
DRDY#	I/O AGTL+	Data Ready: Asserted for each cycle that data is transferred.										
HA[31:3]#	I/O AGTL+	Host Address Bus: HA[31:3]# connect to the system address bus. During processor cycles, HA[31:3]# are inputs. The MCH drives HA[31:3]# during snoop cycles on behalf of the hub interface and AGP/Secondary PCI initiators. HA[31:3]# are transferred at 2x rate. Note that the address is inverted on the system bus.										
HADSTB[1:0]#	I/O AGTL+	<p>Host Address Strobe: The source synchronous strobes used to transfer HA[31:3]# and HREQ[4:0]# at the 2x transfer rate.</p> <table border="0"> <thead> <tr> <th>Strobe</th> <th>Address Bits</th> </tr> </thead> <tbody> <tr> <td>HADSTB0#</td> <td>HA[16:3]#, HREQ[4:0]#</td> </tr> <tr> <td>HADSTB1#</td> <td>HA[31:17]#</td> </tr> </tbody> </table>	Strobe	Address Bits	HADSTB0#	HA[16:3]#, HREQ[4:0]#	HADSTB1#	HA[31:17]#				
Strobe	Address Bits											
HADSTB0#	HA[16:3]#, HREQ[4:0]#											
HADSTB1#	HA[31:17]#											

Signal Name	Type	Description																		
HD[63:0]#	I/O AGTL+	Host Data: These signals are connected to the system data bus. HD[63:0]# are transferred at a 4x rate. Note that the data signals are inverted on the system bus.																		
HDSTBP[3:0]# HDSTBN[3:0]#	I/O AGTL+	Differential Host Data Strobes: The differential source synchronous strobes used to transfer HD[63:0]# and DBI[3:0]# at the 4x transfer rate. <table border="0"> <thead> <tr> <th>Strobe</th> <th>Data Bits</th> </tr> </thead> <tbody> <tr> <td>HDSTBP3#, HDSTBN3#</td> <td>HD[63:48]#, DBI3#</td> </tr> <tr> <td>HDSTBP2#, HDSTBN2#</td> <td>HD[47:32]#, DBI2#</td> </tr> <tr> <td>HDSTBP1#, HDSTBN1#</td> <td>HD[31:16]#, DBI1#</td> </tr> <tr> <td>HDSTBP0#, HDSTBN0#</td> <td>HD[15:0]#, DBI0#</td> </tr> </tbody> </table>	Strobe	Data Bits	HDSTBP3#, HDSTBN3#	HD[63:48]#, DBI3#	HDSTBP2#, HDSTBN2#	HD[47:32]#, DBI2#	HDSTBP1#, HDSTBN1#	HD[31:16]#, DBI1#	HDSTBP0#, HDSTBN0#	HD[15:0]#, DBI0#								
Strobe	Data Bits																			
HDSTBP3#, HDSTBN3#	HD[63:48]#, DBI3#																			
HDSTBP2#, HDSTBN2#	HD[47:32]#, DBI2#																			
HDSTBP1#, HDSTBN1#	HD[31:16]#, DBI1#																			
HDSTBP0#, HDSTBN0#	HD[15:0]#, DBI0#																			
HIT#	I/O AGTL+	Hit: This signal indicates that a caching agent holds an unmodified version of the requested line. HIT# is also driven in conjunction with HITM# by the target to extend the snoop window.																		
HITM#	I/O AGTL+	Hit Modified: This signal indicates that a caching agent holds a modified version of the requested line and that this agent assumes responsibility for providing the line. HITM# is also driven in conjunction with HIT# to extend the snoop window.																		
HLOCK#	I AGTL+	Host Lock: All system bus cycles sampled with the assertion of HLOCK# and ADS#, until the negation of HLOCK# must be atomic (i.e., no hub interface or AGP snoopable access to system memory are allowed when HLOCK# is asserted by the processor).																		
HREQ[4:0]#	I/O AGTL+	Host Request Command: These signals define the attributes of the request. In Enhanced Mode HREQ[4:0]# are transferred at 2x rate. HREQ[4:0]# are asserted by the requesting agent during both halves of Request Phase. In the first half the signals define the transaction type to a level of detail that is sufficient to begin a snoop request. In the second half the signals carry additional information to define the complete transaction type. The transactions supported by the MCH host bridge are defined in the Section 5.1.																		
HTRDY#	O AGTL+	Host Target Ready: HTRDY# indicates that the target of the processor transaction is able to enter the data transfer phase.																		
RS[2:0]#	O AGTL+	Response Status: RS[2:0]# indicates the type of response according to the following table: <table border="0"> <thead> <tr> <th>RS[2:0]</th> <th>Response Type</th> </tr> </thead> <tbody> <tr> <td>000</td> <td>Idle state</td> </tr> <tr> <td>001</td> <td>Retry response</td> </tr> <tr> <td>010</td> <td>Deferred response</td> </tr> <tr> <td>011</td> <td>Reserved (not driven by MCH)</td> </tr> <tr> <td>100</td> <td>Hard Failure (not driven by MCH)</td> </tr> <tr> <td>101</td> <td>No data response</td> </tr> <tr> <td>110</td> <td>Implicit Write back</td> </tr> <tr> <td>111</td> <td>Normal data response</td> </tr> </tbody> </table>	RS[2:0]	Response Type	000	Idle state	001	Retry response	010	Deferred response	011	Reserved (not driven by MCH)	100	Hard Failure (not driven by MCH)	101	No data response	110	Implicit Write back	111	Normal data response
RS[2:0]	Response Type																			
000	Idle state																			
001	Retry response																			
010	Deferred response																			
011	Reserved (not driven by MCH)																			
100	Hard Failure (not driven by MCH)																			
101	No data response																			
110	Implicit Write back																			
111	Normal data response																			

2.2 SDR SDRAM Interface Signals

Signal Name	Type	Description
SCS[11:0]#	O CMOS	Chip Select: These signals select the particular SDRAM components during the active state. Note: There are two SCS# signals per SDRAM row. These signals can be toggled on every rising system memory clock edge.
SMA[12:0]	O CMOS	Multiplexed Memory Address: These signals are used to provide the multiplexed row and column address to SDRAM.
SBS[1:0]	O CMOS	Memory Bank Select: SBS[1:0] define the banks that are selected within each SDRAM row. The SMA and SBS signals combine to address every possible location in a SDRAM device.
SRAS#	O CMOS	SDRAM Row Address Strobe: SRAS# is Used with SCAS# and SWE# (along with SCS#) to define the DRAM commands.
SCAS#	O CMOS	SDRAM Column Address Strobe: SCAS# is used with SRAS# and SWE# (along with SCS#) to define the SDRAM commands.
SWE#	O CMOS	Write Enable: SWE# is used with SCAS# and SRAS# (along with SCS#) to define the SDRAM commands.
SDQ[63:0]	I/O CMOS	Data Lines: These signals are used to interface to the SDRAM data bus.
SCB[7:0]	I/O CMOS	Check Bit Data Lines: These signals are used to interface to the SDRAM ECC signals.
SCKE[5:0]	O CMOS	Clock Enable: These pins are used to signal a self-refresh or Powerdown command to a SDRAM array when entering system suspend. SCKE is also used to dynamically powerdown inactive SDRAM rows. There is one SCKE per SDRAM row. These signals can be toggled on every rising SCLK edge.
RDCLKO	O CMOS	Clock Output: RDCLKO is used to emulate source-synch clocking for reads. This signal connects to RDCLKIN.
RDCLKIN	I CMOS	Clock Input: RDCLKIN is used to emulate source-synch clocking for reads. This signal connects to RDCLKO.

2.3 Hub Interface Signals

Signal Name	Type	Description
HI_[10:0]	I/O CMOS	Hub Interface Signals: Signals used for the hub interface.
HI_STB	I/O CMOS	Hub Interface Strobe: One of two differential strobe signals used to transmit or receive packet data over the hub interface.
HI_STB#	I/O CMOS	Hub Interface Strobe Compliment: One of two differential strobe signals used to transmit or receive packet data over the hub interface.

2.4 AGP Interface Signals

2.4.1 AGP Addressing Signals

Signal Name	Type	Description
PIPE#	I AGP	<p>Pipelined Read: This signal is asserted by the AGP master to indicate a full-width address is to be enqueued on by the target using the AD bus. One address is placed in the AGP request queue on each rising clock edge while PIPE# is asserted. When PIPE# is deasserted, no new requests are queued across the AD bus.</p> <p>During SBA Operation: Not Used.</p> <p>During FRAME# Operation: Not Used.</p> <p>PIPE# is a sustained three-state signal from masters (graphics controller), and is an MCH input.</p> <p>Note: Initial AGP designs may not use PIPE# (i.e., PCI only 66 MHz). Therefore, an 8 kΩ pull-up resistor connected to this pin is required on the motherboard.</p>
SBA[7:0]	I AGP	<p>Sideband Address: These signals are used by the AGP master (graphics controller) to place addresses into the AGP request queue. The SBA bus and AD bus operate independently. That is, a transaction can proceed on the SBA bus and the AD bus simultaneously.</p> <p>During PIPE# Operation: Not Used.</p> <p>During FRAME# Operation: Not Used.</p> <p>Note: When sideband addressing is disabled, these signals are isolated (no external/internal pull-up resistors are required).</p>

NOTE: The above table contains two mechanisms to queue requests by the AGP master. Note that the master can only use one mechanism. The master may not switch methods without a full reset of the system. When PIPE# is used to queue addresses the master is not allowed to queue addresses using the SBA bus. For example, during configuration time, if the master indicates that it can use either mechanism, the configuration software will indicate which mechanism the master will use. Once this choice has been made, the master will continue to use the mechanism selected until the master is reset (and reprogrammed) to use the other mode. This change of modes is not a dynamic mechanism but rather a static decision when the device is first being configured after reset.

2.4.2 AGP Flow Control Signals

Signal Name	Type	Description
RBF#	I AGP	<p>Read Buffer Full: RBF# indicates if the master is ready to accept previously requested low priority read data. When RBF# is asserted, the MCH is not allowed to initiate the return low priority read data. That is, the MCH can finish returning the data for the request currently being serviced. RBF# is only sampled at the beginning of a cycle. If the AGP master is always ready to accept return read data, then it is not required to implement this signal.</p> <p>During FRAME# Operation: Not Used.</p>
WBF#	I AGP	<p>Write-Buffer Full: Indicates if the master is ready to accept fast write data from the MCH. When WBF# is asserted, the MCH is not allowed to drive fast write data to the AGP master. WBF# is only sampled at the beginning of a cycle. If the AGP master is always ready to accept fast write data, then it is not required to implement this signal.</p> <p>During FRAME# Operation: Not Used.</p>

2.4.3 AGP Status Signals

Signal Name	Type	Description
ST[2:0]	O AGP	<p>Status: ST[2:0] provides information from the arbiter to an AGP Master on what it may do. ST[2:0] only have meaning to the master when its G_GNT# is asserted. When G_GNT# is deasserted, these signals have no meaning and must be ignored. Refer to the <i>AGP Interface Specification, Revision 2.0</i> for further explanation of the ST[2:0] values and their meanings.</p> <p>During FRAME# Operation: These signals are not used during FRAME#-based operation, except that a '111' indicates that the master may begin a FRAME# transaction.</p>

2.4.4 AGP Strobes Signals

Signal Name	Type	Description
AD_STB0	I/O (s/t/s) AGP	Address/Data Bus Strobe-0: This signal provides timing for 2x and 4x data on AD[15:0] and the C/BE[1:0]# signals. The agent that is providing the data drives this signal.
AD_STB0#	I/O (s/t/s) AGP	Address/Data Bus Strobe-0 Compliment: Differential strobe pair that provides timing information for the AD[15:0] and C/BE[1:0]# signals. The agent that is providing the data drives this signal.
AD_STB1	I/O (s/t/s) AGP	Address/Data Bus Strobe-1: This signal provides timing for 2x- and 4x-clocked data on AD[31:16] and C/BE[3:2]# signals. The agent that is providing the data drives this signal.
AD_STB1#	I/O (s/t/s) AGP	Address/Data Bus Strobe-1 Compliment: The differential compliment to the AD_STB1 signal. It is used to provide timing for 4x-clocked data.
SB_STB	I AGP	Sideband Strobe: This signal provides timing for 2x- and 4x- clocked data on the SBA[7:0] bus. It is driven by the AGP master after the system has been configured for 2x- or 4x- clocked sideband address delivery.
SB_STB#	I AGP	Sideband Strobe Compliment: SB_STB# is the differential compliment to the SB_STB signal. It is used to provide timing for 4x-clocked data.

2.4.5 AGP/PCI Signals

For transactions on the AGP interface carried using AGP FRAME# protocol, these signals operate similar to their semantics in the PCI 2.1 specification the exact role of all AGP FRAME# signals are defined below.

Signal Name	Type	Description
G_FRAME#	I/O s/t/s AGP	FRAME: During FRAME# Operations, G_FRAME# is an output when the MCH acts as an initiator on the AGP Interface.
G_IRDY#	I/O s/t/s AGP	Initiator Ready#: This signal indicates the AGP compliant master is ready to provide all write data for the current transaction. Once G_IRDY# is asserted for a write operation, the master is not allowed to insert wait states. The master is never allowed to insert a wait state during the initial data transfer (32 bytes) of a write transaction. However, it may insert wait states after each 32-byte block is transferred.
G_TRDY#	I/O s/t/s AGP	Target Ready: This signal indicates the AGP compliant target is ready to provide read data for the entire transaction (when the transfer size is less than or equal to 32 bytes) or is ready to transfer the initial or subsequent block (32 bytes) of data when the transfer size is greater than 32 bytes. The target is allowed to insert wait states after each block (32 bytes) is transferred on write transactions.
G_STOP#	I/O s/t/s AGP	STOP: G_STOP Is an input when the MCH acts as a FRAME#-based AGP initiator and an output when the MCH acts as a FRAME#-based AGP target. G_STOP# is used for disconnect, retry, and abort sequences on the AGP interface.

Signal Name	Type	Description
G_DEVSEL#	I/O s/t/s AGP	Device Select: This signal indicates that a FRAME#-based AGP target device has decoded its address as the target of the current access. The MCH asserts G_DEVSEL# based on the DRAM address range being accessed by a PCI initiator. As an input it indicates whether any device on the bus has been selected.
G_REQ#	I AGP	Request: Indicates that a FRAME# or PIPE#-based AGP master is requesting use of the AGP interface. This signal is an input into the MCH.
G_GNT#	O AGP	Grant: During SBA, PIPE# and FRAME# operation, G_GNT#, along with the information on the ST[2:0] signals (status bus), indicates how the AGP interface will be used next.
G_AD[31:0]	I/O AGP	Address/Data Bus: These signals are used to transfer both address and data on the AGP interface.
G_C/BE[3:0]#	I/O AGP	Command/Byte Enable: During FRAME# Operation: During the address phase of a transaction, G_C/BE[3:0]# define the bus command. During the data phase, G_C/BE[3:0]# are used as byte enables. The byte enables determine which byte lanes carry meaningful data. During PIPE# Operation: When an address is enqueued using PIPE#, the G_C/BE# signals carry command information. The command encoding used during PIPE#-based AGP is DIFFERENT than the command encoding used during FRAME#-based AGP cycles (or standard PCI cycles on a PCI bus).
G_PAR	I/O AGP	Parity: During FRAME# Operations: This signal is driven by the MCH when it acts as a FRAME#-based AGP initiator during address and data phases for a write cycle, and during the address phase for a read cycle. PAR is driven by the MCH when it acts as a FRAME#-based AGP target during each data phase of a FRAME#-based AGP memory read cycle. Even parity is generated across AD[31:0] and G_C/BE[3:0]#. During SBA and PIPE# Operation: This signal is not used during SBA and PIPE# operation.

NOTE: PCIRST# from the ICH2 is connected to RSTIN# and is used to reset AGP interface logic within the MCH. The AGP agent will also use PCIRST# provided by the ICH2 as an input to reset its internal logic.

2.5 Clocks, Reset, and Miscellaneous Signals

Signal Name	Type	Description
BCLK BCLK#	I CMOS	Differential Host Clock In: These pins receive a differential host clock from the external clock synthesizer. This clock is used by all of the MCH logic that is in the host clock domain.
66IN	I CMOS	66 MHz Clock In: This pin receives a 66 MHz clock from the clock synthesizer. This clock is used by AGP/PCI and hub interface clock domains. Note: That this clock input is 3.3 V tolerant.
SCK[11:0]	O CMOS	System Memory Clocks (SDR): These signals deliver a synchronized clock to the DIMMs. There are two per row.
RSTIN#	I CMOS	Reset In: When asserted, this signal asynchronously resets the MCH logic. RSTIN# is connected to the PCIRST# output of the ICH2. All AGP/PCI output and bi-directional signals will also three-state compliant to PCI Rev 2.0 and 2.1 specifications. Note: This input needs to be 3.3 V tolerant.
TESTIN#	I CMOS	Test Input: This pin is used for manufacturing and board level test purposes. Note: This signal has an internal pull-up resistor.

2.6 Voltage Reference and Power Signals

Signal Name	Type	Description
HVREF	Ref	Host Reference Voltage: Reference voltage input for the data, address, and common clock signals of the host AGTL+ interface.
SDREF	Ref	SDRAM Reference Voltage: Reference voltage input for DQ, DQS, RDCLKIN (SDR).
HL_REF	Ref	Hub Interface Reference: Reference voltage input for the hub interface.
AGPREF	Ref	AGP Reference: Reference voltage input for the AGP interface.
HLRCOMP	I/O CMOS	Compensation for Hub Interface: This signal is used to calibrate the hub interface I/O buffers. It is connected to a 40.2 Ω pull-up resistor with 1% tolerance and is pulled up to VCC1_8.
GRCOMP	I/O CMOS	Compensation for AGP: This signal is used to calibrate buffers. It is connected to a 40.2 Ω pull-down resistor with a 1% tolerance.
HRCOMP[1:0]	I/O CMOS	Compensation for Host: These signals are used to calibrate the host AGTL+ I/O buffers. Each signal is connected to a 24.9 Ω pull-down resistor with a 1% tolerance.
HSWNG[1:0]	I CMOS	Host Reference Voltage: Reference voltage input for the compensation logic.
SMRCOMP	I/O CMOS	System Memory RCOMP:
VCC1_5		1.5 V Power Input: These pins are connected to a 1.5 V power source.
VCC1_8		1.8 V Power Input Pins: These pins are connected to a 1.8 V power source.
VCCSM		SDRAM Power Input Pins: These pins are connected to a 3.3 V power source for SDR.
VCCA[1:0]		PLL Power Input Pins: These pins provide power for the PLL.
VTT		AGTL+ Bus Termination Voltage Inputs: These pins provide the AGTL+ bus termination.
VSS		Ground: The VSS pins are the ground pins for the MCH.
VSSA[1:0]		PLL Ground: The VSSA[1:0] pins are the ground pins for the PLL on the MCH.

2.7 Reset States During Reset

Z	Ti-state
ISO	Isolate inputs in inactive state
S	Strap input sampled during assertion or on the de-asserting edge of RSTIN#
H	Driven high
L	Driven low
D	Strong drive (to normal value supplied by core logic if not otherwise stated)
I	Input active

Signal Name	State During RSTIN# Assertion
System Bus Interface	
CPURST#	L
HADSTB[1:0]#	Z/I
AP[1:0]#	Z/I
HA[31:4]#	Z/I
HD[63:0]#	Z/I
HDSTBP[3:0]#	Z/I
HDSTBN[3:0]#	Z/I
DBI[3:0]#	Z/I
ADS#	Z/I
BNR#	Z/I
BPRI#	Z/I
DBSY#	Z/I
DEFER#	Z/I
DRDY#	Z/I
HIT#	Z/I
HITM#	Z/I
HLOCK#	Z/I
HREQ[4:0]#	Z/I
HTRDY#	Z/I
RS[2:0]#	Z/I
BREQ0#	Z/I
HVREF	I

Signal Name	State During RSTIN# Assertion
HLRCOMP	Z
HSWNG	I
SDR System Memory	
SCK[11:0]	Z
SCS[11:0]#	Z
SMA[12:0]	Z
SBS[1:0]	Z
SRAS#	Z
SCAS#	Z
SWE#	Z
SDQ[63:0]	Z/I
SCB[7:0]	Z
SCKE[5:0]	L
RDCKLO	Z
RDCKKIN	I
AGP	
PIPE#	I
SBA[7:0]	ISO/S
RBF#	I
WBF#	I/S
G_REQ#	I
ST[2:0]	L/S
G_GNT#	H/S

Signal Name	State During RSTIN# Assertion
AD_STB[1:0]	Z
AD_STB[1:0]#	Z
SB_STB	I
SB_STB#	I
G_AD[31:0]	Z
G_C/BE[3:0]#	Z
G_FRAME#	Z/I
G_IRDY#	Z/I
G_TRDY#	Z/I
G_STOP#	Z/I
G_DEVSEL#	Z/I
G_PAR	Z
AGPREF	Z
Hub Interface	
HI_[10:0]	Z/I
HI_STB	Z/I
HI_STB#	Z/I
Clocks	
BCLK	I
Miscellaneous	
RSTIN#	I
TESTIN#	I

3 Register Description

The MCH contains two sets of software accessible registers, accessed via the host processor I/O address space:

- Control registers I/O mapped into the processor I/O space, which control access to PCI and AGP configuration space (see Section 3.3).
- Internal configuration registers residing within the MCH are partitioned into two logical device register sets (“logical” since they reside within a single physical device). The first register set is dedicated to Host-HI Bridge functionality (i.e., DRAM configuration, other chip-set operating parameters and optional features). The second register block is dedicated to Host-AGP Bridge functions (controls AGP interface configurations and operating parameters).

The MCH supports PCI configuration space accesses using the mechanism denoted as Configuration Mechanism #1 in the PCI specification.

The MCH internal registers (I/O Mapped and configuration registers) are accessible by the processor. The registers can be accessed as Byte, Word (16-bit), or DWord (32-bit) quantities, with the exception of CONF_ADDR which can only be accessed as a DWord. All multi-byte numeric fields use "little-endian" ordering (i.e., lower addresses contain the least significant parts of the field).

3.1 Register Terminology

Term	Description
RO	Read Only. If a register is read only, writes to this register have no effect.
R/W	Read/Write. A register with this attribute can be read and written.
R/W/L	Read/Write/Lock. A register with this attribute can be read, written, and Locked.
R/WC	Read/Write Clear. A register bit with this attribute can be read and written. However, a write of a 1 clears (sets to 0) the corresponding bit and a write of a 0 has no effect.
R/WO	Read/Write Once. A register bit with this attribute can be written to only once after power up. After the first write, the bit becomes read only.
L	Lock. A register bit with this attribute becomes Read Only after a lock bit is set.
Reserved Bits	Some of the MCH registers described in this section contain reserved bits. These bits are labeled “Reserved”. Software must deal correctly with fields that are reserved. On reads, software must use appropriate masks to extract the defined bits and not rely on reserved bits being any particular value. On writes, software must ensure that the values of reserved bit positions are preserved. That is, the values of reserved bit positions must first be read, merged with the new values for other bit positions and then written back. Note that software does not need to perform a read-merge-write operation for the Configuration Address (CONF_ADDR) register.

Term	Description
Reserved Registers	In addition to reserved bits within a register, the MCH contains address locations in the configuration space that are marked “Reserved”. When a “Reserved” register location is read, a random value is returned. (“Reserved” registers can be 8-, 16-, or 32-bit in size). Registers that are marked as “Reserved” must not be modified by system software. Writes to “Reserved” registers may cause system failure.
Default Value upon a Reset	Upon a Full Reset, the MCH sets all of its internal configuration registers to predetermined default states. Some register values at reset are determined by external strapping options. The default state represents the minimum functionality feature set required to successfully bring up the system. Hence, it does not represent the optimal system configuration. It is the responsibility of the system initialization software (usually BIOS) to properly determine the DRAM configurations, operating parameters and optional system features that are applicable, and to program the MCH registers accordingly.

3.2 PCI Bus Configuration Space Access

The MCH and ICH2 are physically connected by the hub interface. From a configuration standpoint, the hub interface is PCI bus 0. As a result, all devices internal to the MCH and ICH2 appear to be on PCI bus 0. The system’s primary PCI expansion bus is physically attached to the ICH2 and, from a configuration perspective appears to be a hierarchical PCI bus behind a PCI-to-PCI bridge and, therefore, has a programmable PCI Bus number. **Note that the primary PCI bus is referred to as PCI_A in this document and is not PCI bus #0 from a configuration standpoint.** The AGP appears to system software to be a real PCI bus behind PCI-to-PCI bridges resident as devices on PCI bus 0.

The MCH contains two PCI devices within a single physical component. The configuration registers for the four devices are mapped as devices residing on PCI bus 0.

- Device 0: Host-Hub Interface Bridge/DRAM Controller. Logically this appears as a PCI device residing on PCI bus 0. Physically Device 0 contains the standard PCI registers, DRAM registers, the Graphics Aperture controller, and other MCH specific registers.
- Device 1: Host-AGP Bridge. Logically this appears as a “virtual” PCI-to-PCI bridge residing on PCI bus 0. Physically Device 1 contains the standard PCI-to-PCI bridge registers and the standard AGP/PCI configuration registers (including the AGP I/O and memory address mapping).

Table 6 shows the Device # assignment for the various internal MCH devices.

Table 6. Intel® MCH Internal Device Assignments

MCH Function	Bus 0, Device #
DRAM Controller/8 bit HI_A Controller	Device 0
Host-to-AGP Bridge (virtual P2P)	Device 1

NOTE: A physical PCI bus 0 does not exist. The hub interface and the internal devices in the MCH and ICH2, logically constitute PCI Bus 0 to configuration software.

3.2.1 Standard PCI Bus Configuration Mechanism

The PCI Bus defines a slot based "configuration space" that allows each device to contain up to 8 functions with each function containing up to 256 8-bit configuration registers. The PCI specification defines two bus cycles to access the PCI configuration space: Configuration Read and Configuration Write. Memory and I/O spaces are supported directly by the processor. Configuration space is supported by a mapping mechanism implemented within the MCH. The PCI specification defines two mechanisms to access configuration space, Mechanism #1 and Mechanism #2. **The MCH supports only Mechanism #1.**

The configuration access mechanism makes use of the CONF_ADDR Register (at I/O address 0CF8h though 0CFBh) and CONF_DATA register (at I/O address 0CFCh though 0CFFh). To reference a configuration register a DWord I/O write cycle is used to place a value into CONF_ADDR that specifies the PCI bus, the device on that bus, the function within the device, and a specific configuration register of the device function being accessed. CONF_ADDR[31] must be 1 to enable a configuration cycle. CONF_DATA then becomes a window into the four bytes of configuration space specified by the contents of CONF_ADDR. Any read or write to CONF_DATA results in the MCH translating the CONF_ADDR into the appropriate configuration cycle.

The MCH is responsible for translating and routing the processor's I/O accesses to the CONF_ADDR and CONF_DATA registers to internal MCH configuration registers, hub interface or AGP.

3.2.2 Routing Configuration Accesses

The MCH supports two bus interfaces: the hub interface and AGP. PCI configuration cycles are selectively routed to one of these interfaces. The MCH is responsible for routing PCI configuration cycles to the proper interface. PCI configuration cycles to the ICH2 internal devices and Primary PCI (including downstream devices) are routed to the ICH2 via the hub interface. AGP configuration cycles are routed to AGP. The AGP interface is treated as a separate PCI bus from the configuration point of view. Routing of configuration AGP is controlled via the standard PCI-PCI bridge mechanism using information contained within the Primary Bus Number, the Secondary Bus Number, and the Subordinate Bus Number registers of the corresponding PCI-PCI bridge device.

A detailed description of the mechanism for translating processor I/O bus cycles to configuration cycles on one of the buses is described below.

PCI Bus 0 Configuration Mechanism

The MCH decodes the Bus Number (bits 23:16) and the Device Number fields of the CONF_ADDR register. If the Bus Number field of CONF_ADDR is 0, the configuration cycle is targeting a PCI Bus 0 device.

- The Host-HI Bridge entity in the MCH is hardwired as Device 0 on PCI Bus 0.
- The Host-AGP Bridge entity in the MCH is hardwired as Device 1 on PCI Bus 0.

Configuration cycles to any of the MCH's internal devices are confined to the MCH and not sent over the hub interface. Accesses to disabled MCH internal devices are forwarded over the hub interface as Type 0 Configuration Cycles.

Primary PCI and Downstream Configuration Mechanism

If the Bus Number in the CONF_ADDR is non-zero, and is less than the value in the Host-AGP device's Secondary Bus Number register, or greater than the value in the Host-AGP device's Subordinate Bus Number register, the MCH will generate a Type 1 hub interface configuration cycle. The ICH2 compares the non-zero Bus Number with the Secondary Bus Number and Subordinate Bus Number registers of its P2P bridges to determine if the configuration cycle is meant for Primary PCI, or a downstream PCI bus.

AGP Configuration Mechanism

From the chip-set configuration perspective, AGP is seen as a PCI bus interface residing on a Secondary Bus side of the "virtual" PCI-PCI bridges referred to as the MCH Host-AGP bridge. On the Primary Bus side, the "virtual" PCI-PCI bridge is attached to PCI Bus 0. Therefore, the Primary Bus Number register is hardwired to 0. The "virtual" PCI-PCI bridge entity converts Type 1 PCI bus configuration cycles on PCI Bus 0 into Type 0 or Type 1 configuration cycles on the AGP interface. Type 1 configuration cycles on PCI Bus 0 that have a Bus Number that matches the Secondary Bus Number of the MCH's "virtual" Host-to-PCI_B/AGP bridge will be translated into Type 0 configuration cycles on the AGP interface.

If the Bus Number is non-zero, greater than the value programmed into the Secondary Bus Number Register, and less than or equal to the value programmed into the Subordinate Bus Number Register, the MCH will generate a Type 1 PCI configuration cycle on AGP.

3.3 I/O Mapped Registers

The MCH contains two registers that reside in the processor I/O address space: the Configuration Address (CONF_ADDR) register and the Configuration Data (CONF_DATA) register. The Configuration Address register enables/disables the configuration space and determines what portion of configuration space is visible through the configuration data window.

3.3.1 CONF_ADDR—Configuration Address Register

I/O Address:	0CF8h Accessed as a DWord
Default Value:	00000000h
Access:	R/W
Size:	32 bits

CONF_ADDR is a 32 bit register that can be accessed only as a DWord. A Byte or Word reference will "pass through" the Configuration Address register and the hub interface, onto the PCI bus as an I/O cycle. The CONF_ADDR register contains the Bus Number, Device Number, Function Number, and Register Number for which a subsequent configuration access is intended.

Bit	Descriptions
31	<p>Configuration Enable (CFGE).</p> <p>0 = Disable.</p> <p>1 = Enable. Accesses to PCI configuration space are enabled.</p>
30:24	Reserved. These bits are read only and have a value of 0.
23:16	<p>Bus Number. When Bus Number is programmed to 00h, the target of the configuration cycle is a hub interface agent (MCH, ICH2, etc.).</p> <p>The configuration cycle is forwarded to the hub interface, if Bus Number is programmed to 00h and the MCH is not the target (the device number is ≥ 2).</p> <p>If Bus Number is non-zero and matches the value programmed into the Secondary Bus Number Register of device 1, a Type 0 PCI configuration cycle will be generated on AGP.</p> <p>If Bus Number is non-zero, greater than the value in the Secondary Bus Number register of device 1 and less than or equal to the value programmed into the Subordinate Bus Number register of device 1 a Type 1 PCI configuration cycle will be generated on AGP.</p> <p>If Bus Number is non-zero, and does not fall within the ranges enumerated by device 1's Secondary Bus Number or Subordinate Bus Number register, then a hub interface Type 1 configuration cycle is generated.</p>
15:11	<p>Device Number. This field selects one agent on the PCI bus selected by the Bus Number field. When the Bus Number field is 00, the MCH decodes the Device Number field. The MCH is always Device Number 0 for the Host-Hub Interface bridge entity and Device Number 1 for the Host-AGP entity. Therefore, when Bus Number =0 and Device Number=0–1, the internal MCH devices are selected.</p> <p>If the Bus Number is non-zero and matches the value programmed into the Secondary Bus Number register a Type 0 PCI configuration cycle is generated on AGP. The MCH decodes the Device Number field ([15:11]) and assert the appropriate GAD signal as an IDSEL. For PCI-to-PCI Bridge translation, one of the 16 IDSELS is generated. When bit [15] = 0, bits [14:11] are decoded to assert a signal AD[31:16] IDSEL. GAD16 is asserted to access Device 0, GAD17 for Device 1, and so forth up to Device 15 which asserts AD31. All device numbers higher than 15 cause a type 0 configuration access with no IDSEL asserted, which results in a Master Abort reported in the MCH's "virtual" PCI-PCI bridge registers.</p> <p>For Bus Numbers resulting in hub interface configuration cycles, the MCH propagates the device number field as A[15:11]. For bus numbers resulting in AGP type 1 configuration cycles, the device number is propagated as GAD[15:11].</p>
10:8	<p>Function Number. This field is mapped to GAD[10:8] during AGP configuration cycles and A[10:8] during Hub Interface configuration cycles. This allows the configuration registers of a particular function in a multi-function device to be accessed. The MCH ignores configuration cycles to its internal devices if the function number is not equal to 0.</p>
7:2	<p>Register Number. This field selects one register within a particular bus, device, and function as specified by the other fields in the Configuration Address register. This field is mapped to GAD[7:2] during AGP configuration cycles and A[7:2] during hub interface configuration cycles.</p>
1:0	Reserved.

3.3.2 CONF_DATA—Configuration Data Register

I/O Address:	0CFCh
Default Value:	00000000h
Access:	R/W
Size:	32 bits

CONF_DATA is a 32 bit read/write window into configuration space. The portion of configuration space that is referenced by CONF_DATA is determined by the contents of CONF_ADDR.

Bit	Descriptions
31:0	Configuration Data Window (CDW). If bit 31 of the CONF_ADDR register is 1, any I/O access to the CONF_DATA register will be mapped to configuration space using the contents of CONF_ADDR.

3.4 Memory-Mapped Register Space

All system memory control functions have been consolidated into a new memory-mapped address region within Device 0, Function 0. This space will be accessed using a new Base Address register (BAR) located at Device 0, Function 0 (address offset 14h). By default this BAR is invisible (i.e., read-only as 0s).

Note: All accesses to these memory-mapped registers must be made as a single DWord (4 bytes) or less. Access must be aligned on a natural boundary.

The high-level address map for the memory-mapped registers is shown in Table 7.

Table 7. Memory-mapped Register Address Map

Memory Address Offset	Register Group
020h–02Bh	Reserved
2Ch	DRAM Width Register
02Dh–02Fh	Reserved
030h–034h	Strength Registers
040h–0DFh	Reserved
140h–1DFh	Reserved

3.4.1 DRAMWIDTH—DRAM Width Register

Address Offset: 2Ch
 Default Value: 00h
 Access: R/W
 Size: 8 bits

This register determines the width of SDRAM devices populated in each row of memory.

Bit	Descriptions
7:6	Reserved.
5	Row 5 Width. Width of devices in Row 5 0 = 16-bit wide devices, or Unpopulated (default) 1 = 8-bit wide devices
4	Row 4 Width. Width of devices in Row 4 0 = 16-bit wide devices, or Unpopulated (default) 1 = 8-bit wide devices
3	Row 3 Width. Width of devices in Row 3 0 = 16-bit wide devices, or Unpopulated (default) 1 = 8-bit wide devices
2	Row 2 Width. Width of devices in Row 2 0 = 16-bit wide devices, or Unpopulated (default) 1 = 8-bit wide devices
1	Row 1 Width. Width of devices in Row 1 0 = 16-bit wide devices, or Unpopulated (default) 1 = 8-bit wide devices
0	Row 0 Width. Width of devices in Row 0 0 = 16-bit wide devices, or Unpopulated (default) 1 = 8-bit wide devices

Note: Since there are multiple clock signals assigned to each row of a DIMM, it is important to clarify exactly which row width field affects which clock signal.

Row Parameters	SDR Clocks Affected
0	SCK[0], SCK[2]
1	SCK[1], SCK[3]
2	SCK[4], SCK[6]
3	SCK[5], SCK[7]
4	SCK[8], SCK[10]
5	SCK[9], SCK[11]

3.4.2 DQCMDSTR—Strength Control Register (SDQ and CMD Signal Groups)

Memory Address Offset: 30h
 Default Value: 00h
 Access: R/W
 Size: 8 bits

This register controls the drive strength of the I/O buffers for the DQ/DQS and CMD signal groups.

Bit	Descriptions
7	Reserved.
6:4	<p>CMD Strength Control (SRAS#, SCAS#, SWE#, SMA[12:0], SBS[1:0]). This field selects the signal drive strength.</p> <p>000 = 0.75 X (default) 001 = 1.00 X 010 = 1.25 X 011 = 1.50 X 100 = 2.00 X 101 = 2.50 X 110 = 3.00 X 111 = 4.00 X</p>
3	Reserved.
2:0	<p>SDQ/SDQS Strength Control. This field selects the signal drive strength.</p> <p>000 = 0.75 X (default) 001 = 1.00 X 010 = 1.25 X 011 = 1.50 X 100 = 2.00 X 101 = 2.50 X 110 = 3.00 X 111 = 4.00 X</p>

3.4.3 CKESTR—Strength Control Register (SCKE Signal Group)

Memory Address Offset:	31h
Default Value:	00h
Access:	R/W
Size:	8 bits

This register controls the drive strength of the I/O buffers for the CKE signal group. This group has two possible loadings depending on the width of SDRAM devices used in each row of memory (x8 or x16). The proper strength can be independently programmed for each configuration. The actual strength used for each signal is determined by the DRAMWIDTH Register (offset 2Ch).

Bit	Descriptions
7	Reserved.
6:4	<p>SCKE x16 Strength Control. This field selects the signal drive strength.</p> <p>000 = 0.75 X (default)</p> <p>001 = 1.00 X</p> <p>010 = 1.25 X</p> <p>011 = 1.50 X</p> <p>100 = 2.00 X</p> <p>101 = 2.50 X</p> <p>110 = 3.00 X</p> <p>111 = 4.00 X</p>
3	Reserved.
2:0	<p>SCKE x8 Strength Control. This field selects the signal drive strength.</p> <p>000 = 0.75 X (default)</p> <p>001 = 1.00 X</p> <p>010 = 1.25 X</p> <p>011 = 1.50 X</p> <p>100 = 2.00 X</p> <p>101 = 2.50 X</p> <p>110 = 3.00 X</p> <p>111 = 4.00 X</p>

3.4.4 CSBSTR—Strength Control Register (SCS# Signal Group)

Memory Address Offset: 32h
 Default Value: 00h
 Access: R/W
 Size: 8 bits

This register controls the drive strength of the I/O buffers for the SCS# signal group. This group has two possible loadings depending on the width of SDRAM devices used in each row of memory (x8 or x16). The proper strength can be independently programmed for each configuration. The actual strength used for each signal is determined by the DRAMWIDTH Register (offset 2Ch).

Bit	Descriptions
7	Reserved.
6:4	<p>SCS# x16 Strength Control. This field selects the signal drive strength.</p> <p>000 = 0.75 X (default)</p> <p>001 = 1.00 X</p> <p>010 = 1.25 X</p> <p>011 = 1.50 X</p> <p>100 = 2.00 X</p> <p>101 = 2.50 X</p> <p>110 = 3.00 X</p> <p>111 = 4.00 X</p>
3	Reserved.
2:0	<p>SCS# x8 Strength Control. This field selects the signal drive strength.</p> <p>000 = 0.75 X (default)</p> <p>001 = 1.00 X</p> <p>010 = 1.25 X</p> <p>011 = 1.50 X</p> <p>100 = 2.00 X</p> <p>101 = 2.50 X</p> <p>110 = 3.00 X</p> <p>111 = 4.00 X</p>

3.4.5 CKSTR—Strength Control Register (Clock Signal Group)

Memory Address Offset: 33h
 Default Value: 00h
 Access: R/W
 Size: 8 bits

This register controls the drive strength of the I/O buffers for the Clock (CK) signal group including both the CK and CK# signals. This group has two possible loadings depending on the width of SDRAM devices used in each row of memory (x8 or x16). The proper strength can be independently programmed for each configuration. The actual strength used for each signal is determined by the DRAMWIDTH Register (offset 2Ch).

Bit	Descriptions
7	Reserved.
6:4	CK x16 Strength Control. This field selects the signal drive strength. 000 = 0.75 X (default) 001 = 1.00 X 010 = 1.25 X 011 = 1.50 X 100 = 2.00 X 101 = 2.50 X 110 = 3.00 X 111 = 4.00 X
3	Reserved.
2:0	CK x8 Strength Control. This field selects the signal drive strength. 000 = 0.75 X (default) 001 = 1.00 X 010 = 1.25 X 011 = 1.50 X 100 = 2.00 X 101 = 2.50 X 110 = 3.00 X 111 = 4.00 X



3.4.6 RCVENSTR—Strength Control Register (RCVENOUT Signal Group)

Memory Address Offset: 34h
 Default Value: 00h
 Access: R/W
 Size: 8 bits

This register controls the drive strength of the I/O buffers for the Receive Enable Out signal group (RDCLKO# signal).

Bit	Descriptions
7:3	Reserved.
2:0	<p>Receive Enable Out Signal Group (RCVEnOut) Strength Control. This field selects the signal drive strength.</p> <p>000 = 0.75 X (default)</p> <p>001 = 1.00 X</p> <p>010 = 1.25 X</p> <p>011 = 1.50 X</p> <p>100 = 2.00 X</p> <p>101 = 2.50 X</p> <p>110 = 3.00 X</p> <p>111 = 4.00 X</p>

3.5 Host-Hub Interface Bridge Device Registers (Device 0)

Table 8 provides the register address map for Device 0 PCI configuration space. An “s” in the Default Value column indicates that a strap determines the power-up default value for that bit.

Table 8. Intel® MCH Configuration Space (Device 0)

Address Offset	Register Symbol	Register Name	Default Value	Access
00–01h	VID	Vendor Identification	8086h	RO
02–03h	DID	Device Identification	1A30h	RO
04–05h	PCICMD	PCI Command	0006h	RO, R/W
06–07h	PCISTS	PCI Status	0090h	RO, R/WC
08h	RID	Revision Identification	03h, 04h	RO
09h	—	Reserved.	—	—
0Ah	SUBC	Sub-Class Code	00h	RO
0Bh	BCC	Base Class Code	06h	RO
0Dh	MLT	Master Latency Timer	00h	RO
0Eh	HDR	Header Type	00h	RO
0Fh	—	Reserved.	—	—
10–13h	APBASE	Aperture Base Configuration	00000008h	RO, R/W
14–2Bh	—	Reserved.	—	—
2C–2Dh	SVID	Subsystem Vendor Identification	0000h	R/WO
2E–2Fh	SID	Subsystem Identification	0000h	R/WO
30–33h	—	Reserved.	—	—
34h	CAPPTR	Capabilities Pointer	A0h	RO
35–50h	—	Reserved.	—	—
51h	AGPM	AGP Miscellaneous Configuration	00h	R/W
52–5Fh	—	Reserved.	—	—
60–67h	DRB[0:7]	DRAM Row Boundary (8 registers)	00h	R/W
68–6Fh	—	Reserved.	—	—
70–73h	DRA	DRAM Row Attribute (4 registers)	00h	R/W
73–77h	—	Reserved.	—	—
78–7Bh	DRT	DRAM Timing Register	00000010h	R/W
7C–7Fh	DRC	DRAM Controller Mode	0000h	R/W, RO
80–85h	—	Reserved.	—	—
86h	DERRSYN	DRAM Error Syndrome	00h	RO

Address Offset	Register Symbol	Register Name	Default Value	Access
87–8Bh	—	Reserved.	—	—
8C–8Fh	EAP	Error Address Pointer	00000000h	RO
90–96h	PAM[0:6]	Programmable Attribute Map (7 Registers)	0000000000 0000h	RO, R/W
97h	FDHC	Fixed DRAM Hole Control	00h	R/W
98–9Ch	—	Reserved.	—	—
9Dh	SMRAM	System Management RAM Control	02h	RO, R/W, R/W/L
9Eh	ESMRAMC	Extended System Mgmt RAM Control	38h	RO, R/W, R/WC, R/W/L
9Fh	—	Reserved.	—	—
A0–A3h	ACAPID	AGP Capability Identifier	00200002h	RO
A4–A7h	AGPSTAT	AGP Status	1F000216h	RO
A8–ABh	AGPCMD	AGP Command	00000000h	R/W
AC–AFh	—	Reserved.	—	—
B0–B3h	AGPCTRL	AGP Control	00000000h	R/W
B4h	APSIZE	Aperture Size	00h	R/W
B5–B7h	—	Reserved	—	—
B8–BBh	ATTBASE	Aperture Translation Table Base	00000000h	R/W
BCh	AMTT	AGP MTT Control	00h	R/W
BDh	LPTT	AGP Low Priority Transaction Timer	00h	R/W
BE–C3h		Reserved		
C4–C5h	TOM	Top of Low Memory	0000h	R/W
C6–C7h	MCHCFG	MCH Configuration	0000h	R/W, RO
C8–C9h	ERRSTS	Error Status	0000h	R/WC
CA–CBh	ERRCMD	Error Command	0000h	R/W
CC–CDh	SMICMD	SMI Command	0000h	R/W
CE–CFh	SCICMD	SCI Command	0000h	R/W
D0–DDh	—	Reserved.	—	—
DE–DFh	SKPD	Scratchpad Data	0000h	R/W
E0–E3h	—	Reserved.	—	—
E4–E7h	CAPID	Product Specific Capability Identifier	F104A009h	RO
E8–FFh	—	Reserved.	—	—

3.5.1 VID—Vendor Identification Register (Device 0)

Address Offset: 00–01h
 Default Value: 8086h
 Attribute: RO
 Size: 16 bits

The VID Register contains the vendor identification number. This 16-bit register combined with the DID Register uniquely identifies any PCI device. Writes to this register have no effect.

Bit	Description
15:0	Vendor Identification Number. This is a 16-bit value assigned to Intel. Intel VID = 8086h.

3.5.2 DID—Device Identification Register (Device 0)

Address Offset: 02–03h
 Default Value: 1A30h
 Attribute: RO
 Size: 16 bits

This 16-bit register combined with the VID Register uniquely identifies any PCI device. Writes to this register have no effect.

Bit	Description
15:0	Device Identification Number. This is a 16-bit value assigned to the MCH Host-Hub Interface Bridge Function #0.

3.5.3 PCICMD—PCI Command Register (Device 0)

Address Offset:	04–05h
Default:	0006h
Access:	R/W, RO
Size	16 bits

Since MCH Device 0 does not physically reside on PCI0, many of the bits are not implemented.

Bit	Descriptions
15:10	Reserved.
9	Fast Back-to-Back—RO. Not implemented; Hardwired to 0. This bit controls whether or not the master can do fast back-to-back write. Since device 0 is strictly a target this bit is not implemented.
8	SERR Enable (SERRE)—R/W. This bit is a global enable bit for Device 0 SERR messaging. The MCH does not have an SERR# signal. The MCH communicates the SERR# condition by sending a SERR message to the ICH2. 0 =Disable. SERR message is not generated by the MCH for Device 0. 1 =Enable. The MCH is enabled to generate SERR messages over the hub interface for specific Device 0 error conditions that are individually enabled in the ERRCMD Register. The error status is reported in the ERRSTS and PCISTS registers. NOTE: This bit only controls SERR message for the Device 0. Device 1 has its own SERRE bits to control error reporting for error conditions occurring on their respective devices.
7	Address/Data Stepping—RO. Not implemented; Hardwired to 0.
6	Parity Error Enable (PERRE)—RO. Not implemented; Hardwired to 0. The PERR# signal is not implemented by the MCH.
5	VGA Palette Snoop—RO. Not implemented; Hardwired to 0.
4	Memory Write and Invalidate Enable(MWIE)—RO. Not implemented; Hardwired to 0.
3	Special Cycle Enable(SCE)—RO. Not implemented; Hardwired to 0.
2	Bus Master Enable (BME)—RO. Hardwired to 1. The MCH is always enabled as a master on the hub interface.
1	Memory Access Enable (MAE)—RO. Not implemented; Hardwired to 1. The MCH always allows access to system memory.
0	I/O Access Enable (IOAE)—RO. Not implemented; Hardwired to 0.

3.5.4 PCISTS—PCI Status Register (Device 0)

Address Offset:	06–07h
Default Value:	0090h
Access:	RO, R/WC
Size:	16 bits

PCISTS is a 16-bit status register that reports the occurrence of error events on Device 0s on the hub interface. Since MCH Device 0 is the Host-to-hub interface bridge, many of the bits are not implemented.

Bit	Description
15	Reserved.
14	Signaled System Error (SSE)—R/WC. 0 = Software clears this bit by writing a 1 to it. 1 = MCH Device 0 generated an SERR message over the hub interface for any enabled Device 0 error condition. Device 0 error conditions are enabled in the PCICMD and ERRCMD Registers. Device 0 error flags are read/reset from the PCISTS or ERRSTS Registers.
13	Received Master Abort Status (RMAS)—R/WC. 0 = Software clears this bit by writing a 1 to it. 1 = MCH generated a hub interface request that receives a Master Abort completion packet or Master Abort Special Cycle.
12	Received Target Abort Status (RTAS)—R/WC. 0 = Software clears this bit by writing a 1 to it. 1 = MCH generated a hub interface request that receives a Target Abort completion packet or Target Abort Special Cycle.
11	Signaled Target Abort Status (STAS)—RO. Not Implemented; Hardwired to 0. The MCH will not generate a Target Abort hub interface completion packet or special cycle.
10:9	DEVSEL Timing (DEVT)—RO. Hardwired to 00. Hub interface does not comprehend DEVSEL# protocol.
8	Master Data Parity Error Detected (DPD)—RO. Not Implemented; Hardwired to 0. PERR signaling and messaging are not implemented by the MCH.
7	Fast Back-to-Back (FB2B)—RO. Hardwired to 1.
6:5	Reserved.
4	Capability List (CLIST)—RO. 1 = Indicates to the configuration software that this device/function implements a list of new capabilities. A list of new capabilities is accessed via the CAPPTR Register (offset 34h). CAPPTR contains an offset pointing to the start address within configuration space of this device where the AGP Capability standard register resides.
3:0	Reserved.

3.5.5 RID—Revision Identification Register (Device 0)

Address Offset:	08h
Default Value:	See table below
Access:	RO
Size:	8 bits

This register contains the revision number of the MCH Device 0. These bits are read only and writes to this register have no effect.

Bit	Description
7:0	<p>Revision Identification Number. This is an 8-bit value that indicates the revision identification number for the MCH Device 0.</p> <p>03h = A3 Stepping</p> <p>04h = B0 Stepping</p>

3.5.6 SUBC—Sub-Class Code Register (Device 0)

Address Offset:	0Ah
Default Value:	00h
Access:	RO
Size:	8 bits

This register contains the Sub-Class Code for the MCH Device 0.

Bit	Description
7:0	<p>Sub-Class Code (SUBC). This is an 8-bit value that indicates the category of bridge of the MCH.</p> <p>00h = Host bridge.</p>

3.5.7 BCC—Base Class Code Register (Device 0)

Address Offset:	0Bh
Default Value:	06h
Access:	RO
Size:	8 bits

This register contains the Base Class Code of the MCH Device 0.

Bit	Description
7:0	<p>Base Class Code (BASEC). This is an 8-bit value that indicates the Base Class Code for the MCH.</p> <p>06h = Bridge device.</p>

3.5.8 MLT—Master Latency Timer Register (Device 0)

Address Offset: 0Dh
 Default Value: 00h
 Access: RO
 Size: 8 bits

The hub interface does not comprehend the concept of Master Latency Timer. Therefore, this register is not implemented.

Bit	Description
7:0	Hardwired to 00h. Writes have no effect.

3.5.9 HDR—Header Type Register (Device 0)

Address Offset: 0Eh
 Default: 00h
 Access: RO
 Size: 8 bits

This register identifies the header layout of the configuration space.

Bit	Description
7:0	Hardwired to 00h. Writes have no effect.

3.5.10 APBASE—Aperture Base Configuration Register (Device 0)

Offset:	10–13h
Default:	0000_0008h
Access:	R/W, RO
Size:	32 bits

The APBASE is a standard PCI Base Address register that is used to set the base of the Graphics Aperture. The standard PCI Configuration mechanism defines the base address configuration register such that only a fixed amount of space can be requested (dependent on which bits are hardwired to 0 or behave as hardwired to 0). To allow for flexibility (of the aperture), an additional register called APSIZE is used as a “back-end” register to control, which bits of the APBASE will behave as hardwired to 0. This register will be programmed by the MCH specific BIOS code that runs before any of the generic configuration software is run.

Note: Bit 9 of the MCHCFG register is used to prevent accesses to the aperture range before this register is initialized by the configuration software and the appropriate translation table structure has been established in the system memory.

Bit	Description
31:28	Upper Programmable Base Address—R/W. These bits are part of the aperture base set by configuration software to locate the base address of the graphics aperture. They correspond to bits [31:28] of the base address in the processor's address space that will cause a graphics aperture translation to be inserted into the path of any memory read or write. Default = 0000
27:22	Middle “Hardwired”/Programmable Base Address—R/W. These bits are part of the aperture base set by configuration software to locate the base address of the graphics aperture. They correspond to bits [27:4] of the base address in the processor's address space that will cause a graphics aperture translation to be inserted into the path of any memory read or write. These bits can behave as though they were hardwired to 0, if programmed to do so by the APSIZE bits of the APSIZE register. This causes configuration software to understand that the granularity of the graphics aperture base address is either finer or more coarse, depending on the bits set by MCH-specific configuration software in APSIZE.
21:4	Lower “Hardwired” Base Address—RO. Hardwired to 0s. This forces a minimum aperture size selected by this register to be 4 MB.
3	Prefetchable—RO. This bit is hardwired to 1 to identify the Graphics Aperture range as prefetchable as per the <i>PCI Local Bus Specification</i> for the base address registers. There are no side effects on reads, the device returns all bytes on reads, regardless of the byte enables, and the MCH may merge processor writes into this range without causing errors.
2:1	Type—RO. These bits determine addressing type and they are hardwired to “00” to indicate that address range defined by the upper bits of this register can be located anywhere in the 32-bit address space.
0	Memory Space Indicator—RO. Hardwired to 0 to identify aperture range as a memory range.

3.5.11 SVID—Subsystem Vendor Identification (Device 0)

Offset: 2C–2Dh
 Default: 0000h
 Access: R/WO
 Size: 16 bits

This value is used to identify the vendor of the subsystem.

Bit	Description
15:0	Subsystem Vendor ID. (Default = 0000h). This field should be programmed during boot-up. After this field is written once, it becomes read only.

3.5.12 SID—Subsystem Identification (Device 0)

Offset: 2E–2Fh
 Default: 0000h
 Access: R/WO
 Size: 16 bits

This value is used to identify a particular subsystem.

Bit	Description
15:0	Subsystem ID. (Default = 0000h). This field should be programmed during boot-up. After this field is written once, it becomes read only.

3.5.13 CAPPTR—Capabilities Pointer (Device 0)

Offset: 34h
 Default: E4h
 Access: RO
 Size: 8 bits

The CAPPTR provides the offset that is the pointer to the location where the AGP standard registers are located.

Bit	Description
7:0	AGP Standard Register Block Pointer Address. This address pointer indicates to software where it can find the beginning of the AGP register block. E4h = AGP register block beginning address.

3.5.14 AGPM—AGP Miscellaneous Configuration Register (Device 0)

Address Offset: 51h
 Default Value: 00h
 Access: R/W
 Size: 8 bits

Bit	Descriptions
7:2	Reserved.
1	Aperture Access Global Enable (APEN). This bit is used to prevent access to the graphics aperture from any port (processor, hub interface, or AGP/PCI_B) before the aperture range is established by the configuration software and the appropriate translation table in system memory has been initialized. The default value is 0; thus, this field must be set after system is fully configured to enable aperture accesses.

3.5.15 DRB[0:7]—DRAM Row Boundary Registers (Device 0)

Offset: 60–67h (DRB0–DRB7)
 Default: 00h
 Access: R/W
 Size: 8 bits

The DRAM Row Boundary Register defines the upper boundary address of each pair of DRAM rows with a granularity of 32 MB. Each row has its own single-byte DRB register. For example, a value of 1 in DRB0 indicates that 32 MB of DRAM has been populated in the first row.

Row 0 = 60h
 Row 1 = 61h
 Row 2 = 62h
 Row 3 = 63h
 Row 4 = 64h
 Row 5 = 65h (See Note 1)
 Row 6 = 66h (See Note 2)
 Row 7 = 67h (See Note 2)

DRB0 = Total memory in row0 (in 32 MB increments)
 DRB1 = Total memory in row0 + row1 (in 32 MB increments)

Notes:

- DRB5 = Total memory in row0 + row1 + row2 + row3 + row4 + row5 (in 32 MB increments)
- DRB [7:6] must be programmed with the value contained in DRB5

Each Row is represented by a byte. Each byte has the following format.

Bit	Description
7:0	DRAM Row Boundary Address. This 8 bit value defines the upper and lower addresses for each DRAM row. This 8-bit value is compared against a set of address lines to determine the upper address limit of a particular row.

3.5.16 DRA—DRAM Row Attribute Registers (Device 0)

Offset: 70–73h (DRA0–DRA3)
 Default: 00h
 Access: R/W
 Size: 8 bits

The DRAM Row Attribute Register defines the page sizes to be used when accessing different pairs of rows. Each nibble of information in the DRA registers describes the page size of a pair of rows:

Row 0, 1 = 70h

Row 2, 3 = 71h

Row 4, 5 = 72h (Used for SDRAM configuration only)

Row 6, 7 = 73h (RAODD and RAEVEN fields must contain default value of 00h)

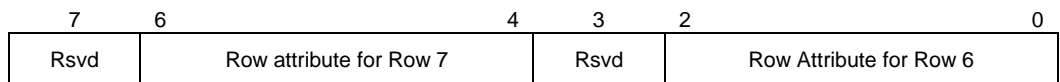
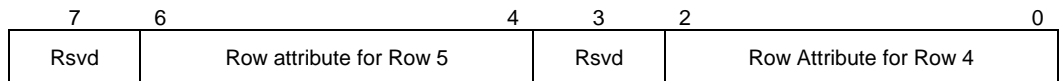
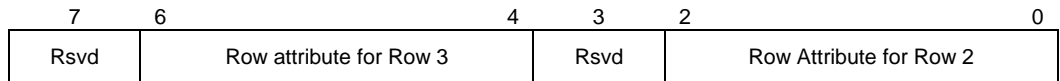
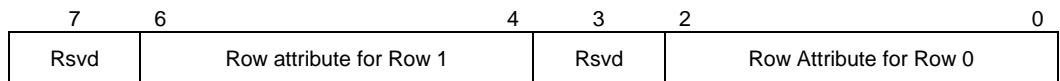

Bit	Description
7	Reserved.
6:4	Row Attribute for Odd-Numbered Row (RAODD). This 3-bit field defines the page size of the corresponding row. 001 = 2 KB 010 = 4 KB 011 = 8 KB 100 = 16 KB Others = Reserved
3	Reserved.
2:0	Row Attribute for Even-Numbered Row (RAEVEN). This 3-bit field defines the page size of the corresponding row. 001 = 2 KB 010 = 4 KB 011 = 8 KB 100 = 16 KB Others = Reserved

3.5.17 DRT—DRAM Timing Register (Device 0)

Offset: 78–7Bh
 Default: 00000010h
 Access: R/W
 Size: 32 bits

Bit	Description
31:19	Reserved.
18:16	<p>DRAM Idle Timer. This field determines the number of clocks the DRAM controller will remain in the idle state before it begins precharging all pages.</p> <p>000 = <i>infinite</i>. 001 = 0 DRAM clocks 010 = 8 DRAM clocks 011 = 16 DRAM clocks 100 = 64 DRAM clocks Others = Reserved</p>
15:11	Reserved.
10:9	<p>Activate to Precharge delay (tRAS). This bit controls the number of DRAM clocks for tRAS.</p> <p>00 = 7 clocks 01 = 6 clocks 10 = 5 clocks 11 = Reserved</p>
8:6	Reserved.
5:4	<p>CAS# Latency (tCL). This bit controls the number of DRAM clocks between when a read command is sampled by the SDRAMs and when the MCH samples read data from the SDRAMs.</p> <p>00 = Reserved 01 = 3 clocks 10 = 2 clocks 11 = Reserved</p>
3	Reserved.
2	<p>DRAM RAS# to CAS# Delay (tRCD). This bit controls the number of clocks inserted between a row activate command and a read or write command to that row.</p> <p>0 = 3 DRAM clocks 1 = 2 DRAM clocks</p>
1	Reserved.
0	<p>DRAM RAS# Precharge (tRP). This bit controls the number of clocks that are inserted between a row precharge command and an activate command to the same row.</p> <p>0 = 3 DRAM clocks 1 = 2 DRAM clocks</p>

3.5.18 DRC—DRAM Controller Mode Register (Device 0)

Offset: 7C–7Fh
 Default: 00000000h
 Access: R/W, RO
 Size: 32 bits

Bit	Description
31:30	Revision Number (REV)—R/W. Reflects the revision number of the format used for SDRAM register definition. Currently, this field must be 00, since this revision (rev 00) is the only existing version of the specification.
29	Initialization Complete (IC)—R/W. This bit is used for communication of software state between the memory controller and the BIOS. BIOS sets this bit to 1 after initialization of the DRAM memory array is complete.
28	Dynamic Powerdown Mode Enable—R/W. When set, the system memory controller will put a pair of rows into powerdown mode when all banks are pre-charged (closed). Once a bank is accessed, the relevant pair of rows is taken out of powerdown mode. The entry into powerdown mode is performed by de-activation of CKE. The exit is performed by activation of CKE. 0 = Disable. System memory powerdown disabled 1 = Enable. System memory powerdown enabled Note: Dynamic powerdown is a mobile only feature and not supported on desktop applications.
27:24	Active SDRAM Rows—R/W. Implementations may use this field to limit the maximum number of SDRAM rows that may be active at once. 0000 = All rows allowed to be in the active state Others = Reserved.
23:22	Reserved.
21:20	DRAM Data Integrity Mode (DDIM)—R/W. These bits select the system memory data integrity mode. 00 = Non-ECC mode 10 = Error checking with correction Other = Reserved
19:11	Reserved.
10:8	Refresh Mode Select (RMS)—R/W. This field determines whether refresh is enabled and, if so, at what rate refreshes will be executed. 000 = Reserved 001 = Refresh enabled. Refresh interval 15.6 us 010 = Refresh enabled. Refresh interval 7.8 us 011 = Refresh enabled. Refresh interval 64 us 111 = Refresh enabled. Refresh interval 64 clocks (fast refresh mode) Other = Reserved
7	Reserved.

Bit	Description
6:4	<p>Mode Select (SMS)—R/W. These bits select the special operational mode of the system memory interface. The special modes are intended for initialization at power up.</p> <p>000 = Post Reset state. When the MCH exits reset (power-up or otherwise), the mode select field is cleared to “000”.</p> <p>During any reset sequence, while power is applied and reset is active, the MCH asserts all CKE signals. After internal reset is deasserted, CKE signals remain deasserted until this field is written to a value different than “000”. On this event, all CKE signals are asserted.</p> <p>During suspend, MCH internal signal triggers system memory controller to flush pending commands and enter all rows into Self-Refresh mode. As part of resume sequence, the MCH will be reset (which will clear this bit field to “000” and maintain CKE signals deasserted). After internal reset is deasserted, CKE signals remain deasserted until this field is written to a value different than “000”. On this event, all CKE signals are asserted.</p> <p>During entry to other low power states (C3, S1), MCH internal signal triggers DRAM controller to flush pending commands and enter all rows into Self-Refresh mode. During exit to normal mode, MCH signal triggers DRAM controller to exit Self-Refresh and resume normal operation without S/W involvement.</p> <p>001 = NOP Command Enable. All processor cycles to system memory result in a NOP command on the system memory interface.</p> <p>010 = All Banks Pre-charge Enable. All processor cycles to system memory result in an “all banks precharge” command on the system memory interface.</p> <p>011 = Mode Register Set Enable. All processor cycles to system memory result in a “mode register” set command on the system memory interface. Host address lines are mapped to memory address lines to specify the command sent. Host address lines [15:3] are mapped to SMA[12:0].</p> <p>100 = Reserved</p> <p>101 = Reserved</p> <p>110 = CBR Refresh Enable. In this mode all processor cycles to system memory result in a CBR cycle on the SDRAM interface</p> <p>111 = Normal operation.</p>
3:2	Reserved.
1:0	<p>DRAM Type (DT)—RO. Used to select between supported SDRAM types.</p> <p>00 = Single Data Rate (SDR) SDRAM.</p> <p>01–11 = Reserved</p>

3.5.19 DERRSYN—DRAM Error Syndrome Register (Device 0)

Address Offset:	86h
Default Value:	00h
Access:	RO
Size:	8 bits

This register is used to report the ECC syndromes for each quadword of a 32 byte-aligned data quantity read from the system memory array.

Bit	Description
7:0	<p>DRAM ECC Syndrome (DECCSYN). After a system memory ECC error, hardware loads this field with a syndrome that describes the set of bits found to be in error.</p> <p>Note: This field is locked from the time that it is loaded up to the time when the error flag is cleared by software. If the first error was a single bit, correctable error, then a subsequent multiple bit error will overwrite this field. In all other cases, an error that occurs after the first error and before the error flag has been cleared by software will escape recording.</p>

3.5.20 EAP—Error Address Pointer Register (Device 0)

Address Offset:	8C–8Fh
Default Value:	0000_0000h
Access:	RO
Size:	32 bits

This register contains the address of the 32 byte-aligned data unit on which system memory ECC error(s) was detected.

Bit	Descriptions
31:30	Reserved.
29:1	<p>Error Address Pointer (EAP). This field is used to store address bits A[33:5] of the 32-byte-aligned data unit of system memory of which an error (single bit or multi-bit error) has occurred.</p> <p>Note: The value of this bit field represents the address of the first single or the first multiple bit error occurrence after the error flag bits in the ERRSTS register have been cleared by software. A multiple bit error will overwrite a single bit error. Once the error flag bits are set as a result of an error, this bit field is locked and does not change as a result of a new error until the error flag is cleared by software.</p>
0	Reserved.

3.5.21 PAM[0:6]—Programmable Attribute Map Registers (Device 0)

Address Offset:	90–96h (PAM0–PAM6)
Default Value:	00h
Attribute:	R/W, RO
Size:	8 bits

The MCH allows programmable memory attributes on 13 Legacy memory segments of various sizes in the 640 Kbytes to 1 Mbytes address range. Seven Programmable Attribute Map (PAM) Registers are used to support these features. Cacheability of these areas is controlled via the MTRR registers in the processor. Two bits are used to specify memory attributes for each memory segment. These bits apply to host initiator only access to the PAM areas. The MCH forwards to system memory for any AGP, PCI or hub interface-initiated accesses to the PAM areas. These attributes are:

- RE - Read Enable.** When RE = 1, the host read accesses to the corresponding memory segment are claimed by the MCH and directed to system memory. Conversely, when RE = 0, the host read accesses are directed to PCI0.
- WE - Write Enable.** When WE = 1, the host write accesses to the corresponding memory segment are claimed by the MCH and directed to system memory. Conversely, when WE = 0, the host write accesses are directed to PCI0.

The RE and WE attributes permit a memory segment to be Read Only, Write Only, Read/Write, or disabled. For example, if a memory segment has RE = 1 and WE = 0, the segment is Read Only.

Each PAM Register controls two regions, typically 16 KB in size. Each of these regions has a 4-bit field. The four bits that control each region have the same encoding and defined in the following table.

Bits [7, 3] Reserved	Bits [6, 2] Reserved	Bits [5, 1] WE	Bits [4, 0] RE	Description
X	X	0	0	Disabled. System memory is disabled and all accesses are directed to the hub interface. The MCH does not respond as a PCI target for any read or write access to this area.
X	X	0	1	Read Only. Reads are forwarded to system memory and writes are forwarded to the hub interface for termination. This write protects the corresponding memory segment. The MCH responds as an AGP or hub interface target for read accesses but not for any write accesses.
X	X	1	0	Write Only. Writes are forwarded to system memory and reads are forwarded to the hub interface for termination. The MCH responds as an AGP or hub interface target for write accesses but not for any read accesses.
X	X	1	1	Read/Write. This is the normal operating mode of system memory. Both read and write cycles from the host are claimed by the MCH and forwarded to system memory. The MCH responds as an AGP or hub interface target for both read and write accesses.

At the time that a hub interface or AGP accesses to the PAM region may occur, the targeted PAM segment must be programmed to be both readable and writeable.

As an example, consider BIOS that is implemented on the expansion bus. During the initialization process, the BIOS can be shadowed in system memory to increase the system performance. When BIOS is shadowed in system memory, it should be copied to the same address location. To shadow the BIOS, the attributes for that address range should be set to write only. BIOS is shadowed by first performing a read of that address. This read is forwarded to the expansion bus. The host then does a write of the same address, which is directed to system memory. After the BIOS is shadowed, the attributes for that memory area are set to read only so that all writes are forwarded to the expansion bus. Table 9 and Figure 2 show the PAM registers and the associated attribute bits:

Figure 2. PAM Register Attributes

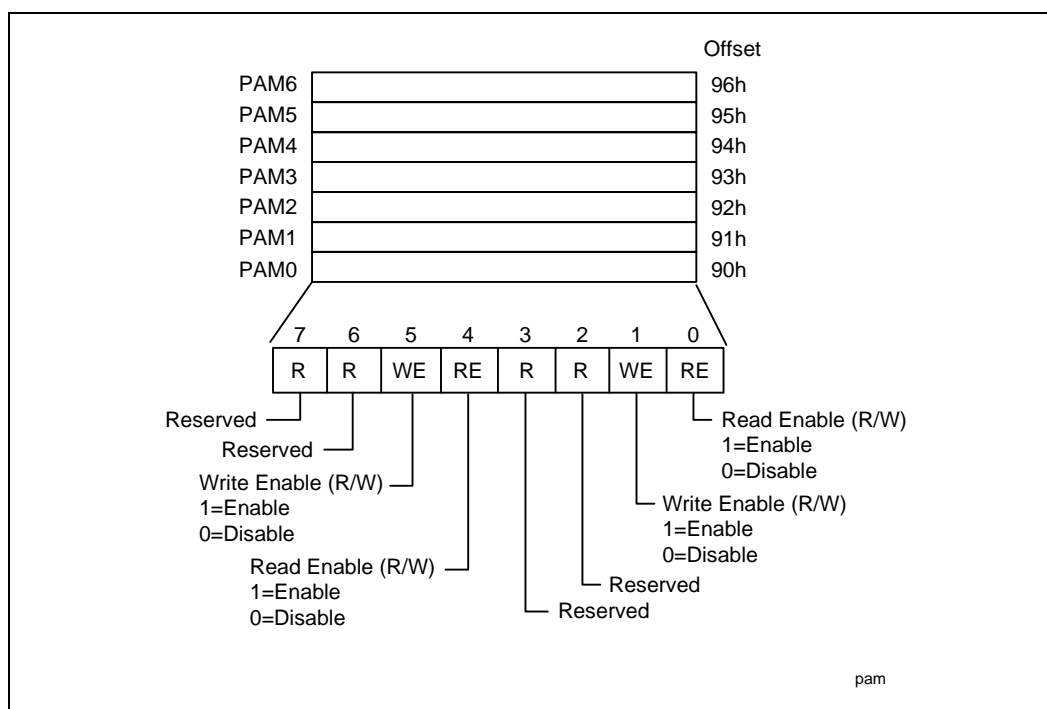

Table 9. PAM Register Attributes

PAM Reg	Attribute Bits				Memory Segment	Comments	Offset
PAM0[3:0]	Reserved						90h
PAM0[7:4]	R	R	WE	RE	0F0000h–0FFFFFFh	BIOS Area	90h
PAM1[3:0]	R	R	WE	RE	0C0000h–0C3FFFh	ISA Add-on BIOS	91h
PAM1[7:4]	R	R	WE	RE	0C4000h–0C7FFFh	ISA Add-on BIOS	91h
PAM2[3:0]	R	R	WE	RE	0C8000h–0CBFFFh	ISA Add-on BIOS	92h
PAM2[7:4]	R	R	WE	RE	0CC000h–0CFFFFh	ISA Add-on BIOS	92h
PAM3[3:0]	R	R	WE	RE	0D0000h–0D3FFFh	ISA Add-on BIOS	93h
PAM3[7:4]	R	R	WE	RE	0D4000h–0D7FFFh	ISA Add-on BIOS	93h
PAM4[3:0]	R	R		RE	0D8000h–0DBFFFh	ISA Add-on BIOS	94h
PAM4[7:4]	R	R	WE	RE	0DC000h–0DFFFFh	ISA Add-on BIOS	94h
PAM5[3:0]	R	R	WE	RE	0E0000h–0E3FFFh	BIOS Extension	95h
PAM5[7:4]	R	R	WE	RE	0E4000h–0E7FFFh	BIOS Extension	95h
PAM6[3:0]	R	R	WE	RE	0E8000h–0EBFFFh	BIOS Extension	96h
PAM6[7:4]	R	R	WE	RE	0EC000h–0EFFFFh	BIOS Extension	96h

For details on overall system address mapping scheme see Chapter 4.

DOS Application Area (00000h–9FFFh)

The DOS area is 640 KB in size and it is further divided into two parts. The 512 KB area at 0h to 7FFFFh is always mapped to the system memory controlled by the MCH, while the 128 KB address range from 080000 to 09FFFFh can be mapped to PCI0 or to system memory. By default this range is mapped to system memory and can be declared as a system memory hole (accesses forwarded to PCI0) via MCH FDHC configuration register.

Video Buffer Area (A0000h–BFFFFh)

Attribute bits do not control this 128 KB area. The host -initiated cycles in this region are always forwarded to either PCI0 or AGP unless this range is accessed in SMM mode. **Routing of accesses is controlled by the Legacy VGA control mechanism of the “virtual” PCI-PCI bridge device embedded within the MCH.**

This area can be programmed as SMM area via the SMRAM register. When used as a SMM space, this range cannot be accessed from the hub interface or AGP.

Expansion Area (C0000h–DFFFFh)

This 128 KB area is divided into eight 16 KB segments, which can be assigned with different attributes via PAM control register as defined by the table above.



Extended System BIOS Area (E0000h–EFFFFh)

This 64 KB area is divided into four 16 KB segments that can be assigned with different attributes via PAM control register as defined by the table above.

System BIOS Area (F0000h–FFFFFh)

This area is a single 64 KB segment, which can be assigned with different attributes via PAM control register as defined by the table above.

3.5.22 FDHC—Fixed DRAM Hole Control Register (Device 0)

Address Offset: 97h
 Default Value: 00h
 Access: R/W
 Size: 8 bits

This 8-bit register controls a fixed DRAM hole: 15–16 MB.

Bit	Description
7	<p>Hole Enable (HEN). This bit enables a memory hole in DRAM space. Host cycles matching an enabled hole are passed on to the ICH2 through the hub interface. The hub interface cycles matching an enabled hole will be ignored by the MCH. Note that a selected hole is not re-mapped.</p> <p>0 = Disabled. No hole 1 = 15 MB–16 MB (1 MB hole)</p>
6:0	Reserved.

3.5.23 SMRAM—System Management RAM Control Register (Device 0)

Address Offset:	9Dh
Default Value:	02h
Access:	R/W, RO, R/W/L
Size:	8 bits

The SMRAMC register controls how accesses to Compatible and Extended SMRAM spaces are treated. The Open, Close, and Lock bits function only when the G_SMROME bit is set to a 1. Also, the OPEN bit must be reset before the LOCK bit is set.

Bit	Description
7	Reserved.
6	SMM Space Open (D_OPEN)—R/W/L. When D_OPEN=1 and D_LCK=0, the SMM space DRAM is made visible even when SMM decode is not active. This is intended to help BIOS initialize SMM space. Software should ensure that D_OPEN=1 and D_CLS=1 are not set at the same time. When D_LCK is set to a 1, D_OPEN is reset to 0 and becomes read only.
5	SMM Space Closed (D_CLS)—R/W. When D_CLS = 1, SMM space DRAM is not accessible to data references, even if SMM decode is active. Code references may still access SMM space DRAM. This allows SMM software to reference “through” SMM space to update the display, even when SMM is mapped over the VGA range. Software should ensure that D_OPEN=1 and D_CLS=1 are not set at the same time. Note that the D_CLS bit only applies to Compatible SMM space.
4	SMM Space Locked (D_LCK)—R/W. When D_LCK is set to 1, D_OPEN is reset to 0 and D_LCK, D_OPEN, C_BASE_SEG, H_SMRAM_EN, TSEG_SZ and TSEG_EN become “Read Only”. D_LCK can be set to 1 via a normal configuration space write but can only be cleared by a Full Reset. The combination of D_LCK and D_OPEN provide convenience with security. The BIOS can use the D_OPEN function to initialize SMM space and then use D_LCK to “lock down” SMM space in the future so that no application software (or BIOS itself) can violate the integrity of SMM space, even if the program has knowledge of the D_OPEN function.
3	Global SMRAM Enable (G_SMROME)—R/W/L. 0 =Disable 1 =Enable. Compatible SMRAM functions are enabled, providing 128 KB of DRAM accessible at the A0000h address while in SMM (ADS# with SMM decode). To enable Extended SMRAM function this bit has to be set to 1. Once D_LCK is set, this bit becomes read only.
2:0	Compatible SMM Space Base Segment (C_BASE_SEG)—RO. This field indicates the location of SMM space. “SMM DRAM” is not remapped. It is simply “made visible” if the conditions are right to access SMM space, otherwise the access is forwarded to the hub interface. 010 = Hardwired to 010 to indicate that the MCH supports the SMM space at A0000h–BFFFFh.

3.5.24 ESMRAMC—Extended System Mgmt RAM Control Register (Device 0)

Address Offset:	9Eh
Default Value:	38h
Access:	RO, R/W, R/WC, R/W/L
Size:	8 bits

The Extended SMRAM register controls the configuration of Extended SMRAM space. The Extended SMRAM (E_SMRAM) memory provides a write-back cacheable SMRAM memory space that is above 1 MB.

Bit	Description
7	<p>H_SMRAM_EN (H_SMRAME)—R/W/L. Controls the SMM memory space location (i.e., above 1 MB or below 1 MB). When G_SMRAME is 1 and H_SMRAME this bit is set to 1, the high SMRAM memory space is enabled. SMRAM accesses from FEDA_0000h to FEDB_FFFFh are remapped to DRAM address 000A0000h to 000BFFFFh.</p> <p>Once D_LCK is set, this bit becomes read only.</p>
6	<p>E_SMRAM_ERR (E_SMERR)—R/WC.</p> <p>0 = The software must write a 1 to this bit to clear it.</p> <p>1 = This bit is set when host accesses the defined memory ranges in Extended SMRAM (High Memory and T-segment) while not in SMM space and with the D-OPEN bit = 0.</p>
5	<p>SMRAM_Cache (SM_CACHE)—RO. Hardwired to 1.</p>
4	<p>SMRAM_L1_EN (SM_L1)—RO. Hardwired to 1.</p>
3	<p>SMRAM_L2_EN (SM_L2)—RO. Hardwired to 1.</p>
2:1	<p>TSEG_SZ[1:0] (T_SZ)—R/W. Selects the size of the TSEG memory block if enabled. This memory is taken from the top of system memory space (i.e., TOM – TSEG_SZ), which is no longer claimed by the memory controller (all accesses to this space are sent to the hub interface if TSEG_EN is set). This field decodes as follows:</p> <p>00 = (TOM–128 KB) to TOM</p> <p>01 = (TOM–256 KB) to TOM</p> <p>10 = (TOM–512 KB) to TOM</p> <p>11 = (TOM–1 MB) to TOM</p> <p>Once D_LCK is set, this bit becomes read only.</p>
0	<p>TSEG_EN (T_EN)—R/W/L. Enabling of SMRAM memory (TSEG, 128 KB, 256 KB, 512 KB or 1 MB of additional SMRAM memory) for Extended SMRAM space only. When G_SMRAME = 1 and TSEG_EN = 1, the TSEG is enabled to appear in the appropriate physical address space.</p> <p>Once D_LCK is set, this bit becomes read only.</p>

3.5.25 ACAPID—AGP Capability Identifier Register (Device 0)

Address Offset:	A0–A3h
Default Value:	0020_0002h
Access:	RO
Size:	32 bits

This register provides standard identifier for AGP capability.

Bit	Description
31:24	Reserved.
23:20	Major AGP Revision Number (MAJREV). These bits provide a major revision number of AGP specification that this version of the MCH conforms. This field is hardwired to value of “0010b” (i.e., implying Rev 2.x).
19:16	Minor AGP Revision Number (MINREV). These bits provide a minor revision number of AGP specification that this version of the MCH conforms. This number is hardwired to value of “0000” (i.e., implying Rev x.0) Together with the major revision number this field identifies MCH as an AGP Revision 2.0 compliant device.
15:8	Next Capability Pointer (NCAPTR). AGP capability is the first and the last capability described via the capability pointer mechanism; therefore, these bits are hardwired to 0h to indicate the end of the capability linked list.
7:0	AGP Capability ID (CAPID). This field identifies the linked list item as containing AGP registers. This field has a value of 0000_0010b assigned by the PCI SIG.

3.5.26 AGPSTAT—AGP Status Register (Device 0)

Address Offset: A4–A7h
 Default Value: 1F00_0217h
 Access: RO
 Size: 32 bits

This register reports AGP device capability/status.

Bit	Description
31:24	Request Queue (RQ). This field contains the maximum number of AGP command requests the MCH is configured to manage. 1Fh = Allows a maximum of 32 outstanding AGP command requests.
23:10	Reserved.
9	Side Band Addressing Support (SBA). Hardwired to 1 to indicate that the MCH supports side band addressing.
8:6	Reserved.
5	Greater than 4 GB Support (4G). Hardwired to 0 to indicate that the MCH does not support addresses greater than 4.
4	Fast Write Support (FW). Hardwired to 1 to indicate that the MCH supports Fast Writes from the host to the AGP master.
3	Reserved.
2:0	Data Rate Support (RATE). Hardwired to 111. After reset, the MCH reports its data transfer rate capability. Bit 0 identifies if AGP device supports 1x data transfer mode, bit 1 identifies if AGP device supports 2x data transfer mode, bit 2 identifies if AGP device supports 4x data transfer mode. 111 = 1x, 2x, and 4x data transfer modes are supported by the MCH Note: The selected data transfer mode applies to both AD bus and SBA bus. It also applies to Fast Writes if they are enabled.

3.5.27 AGPCMD—AGP Command Register (Device 0)

Address Offset: A8–ABh
 Default Value: 0000_0000h
 Access: R/W
 Size: 32 bits

This register provides control of the AGP operational parameters.

Bit	Description
31:10	Reserved.
9	SideBand Address Enable (SBAEN). 0 = Disable. 1 = Enable.
8	AGP Enable (AGPEN). 0 = The MCH ignores all AGP operations, including the sync cycle. Any AGP operation received while this bit is 1 will be serviced, even if this bit is set to 0. If this bit transitions from a 1 to a 0 on a clock edge in the middle of an SBA command being delivered in 1X mode, the command will be issued. 1 = The MCH will respond to AGP operations delivered via PIPE# or to operations delivered via SBA if the AGP Side Band Enable bit is also set to 1.
7:5	Reserved.
4	Fast Write Enable (FWEN). 0 = When this bit is set to 0, or when the data rate bits are set to 1x mode, the memory write transactions from the MCH to the AGP master use standard PCI protocol. 1 = MCH uses the Fast Write protocol for memory write transactions from the MCH to the AGP master. Fast Writes occur at the data transfer rate selected by the DRATE bits (2:0) in this register.
3	Reserved.
2:0	Data Rate (DRATE). The settings of these bits determine the AGP data transfer rate. One (and only one) bit in this field must be set to indicate the desired data transfer rate. 001 = 1x transfer mode 010 = 2x transfer mode 100 = 4x transfer mode Configuration software updates this field by setting only one bit that corresponds to the capability of AGP master (after that capability has been verified by accessing the same functional register in the AGP masters' configuration space.) Note: This field applies to AD and SBA buses. It also applies to Fast Writes if they are enabled.

3.5.28 AGPCTRL—AGP Control Register (Device 0)

Address Offset: B0–B3h
 Default Value: 0000_0000h
 Access: R/W
 Size: 32 bits

This register provides for additional control of the AGP interface.

Bit	Description
31:8	Reserved.
7	GTLB Enable (GTLBEN). This bit provides enable and flush control of the GTLB. 0 =Disable (Default). GTLB is flushed by clearing the valid bits associated with each entry. 1 =Enable. Normal operations of the Graphics Translation Lookaside Buffer.
6:1	Reserved.
0	Data Rate 4x Override. 1 =The RATE[2:0] bit in the AGPSTS register will be read as a 001. This bit allows the BIOS to force 1x mode. Note that this bit must be set by the BIOS before AGP configuration.

3.5.29 APSIZE—Aperture Size (Device 0)

Address Offset: B4h
 Default Value: 00h
 Access: R/W
 Size: 8 bits

This register determines the effective size of the Graphics Aperture used for a particular MCH configuration. This register can be updated by the MCH specific BIOS configuration sequence before the PCI standard bus enumeration sequence takes place. If the register is not updated, the default value will select an aperture of maximum size (i.e., 256 MB). The size of the table that will correspond to a 256 MB aperture is not practical for most applications; therefore, these bits must be programmed to a smaller practical value that will force adequate address range to be requested via APBASE register from the PCI configuration software.

Bit	Description																																																								
7:6	Reserved.																																																								
5:0	<p>Graphics Aperture Size (APSIZE). Each bit in APSIZE[5:0] operates on similarly ordered bits in APBASE[27:22] of the Aperture Base configuration register. When a particular bit of this field is 0, it forces the similarly ordered bit in APBASE[27:22] to behave as “hardwired” to 0. When a particular bit of this field is set to 1, it allows corresponding bit of the APBASE[27:22] to be read/write accessible. Only the following combinations are allowed:</p> <table border="1"> <thead> <tr> <th>5</th> <th>4</th> <th>3</th> <th>2</th> <th>1</th> <th>0</th> <th>Aperture Size</th> </tr> </thead> <tbody> <tr> <td>1</td> <td>1</td> <td>1</td> <td>1</td> <td>1</td> <td>1</td> <td>4 MB</td> </tr> <tr> <td>1</td> <td>1</td> <td>1</td> <td>1</td> <td>1</td> <td>0</td> <td>8 MB</td> </tr> <tr> <td>1</td> <td>1</td> <td>1</td> <td>1</td> <td>0</td> <td>0</td> <td>16 MB</td> </tr> <tr> <td>1</td> <td>1</td> <td>1</td> <td>0</td> <td>0</td> <td>0</td> <td>32 MB</td> </tr> <tr> <td>1</td> <td>1</td> <td>0</td> <td>0</td> <td>0</td> <td>0</td> <td>64 MB</td> </tr> <tr> <td>1</td> <td>0</td> <td>0</td> <td>0</td> <td>0</td> <td>0</td> <td>128 MB</td> </tr> <tr> <td>0</td> <td>0</td> <td>0</td> <td>0</td> <td>0</td> <td>0</td> <td>256 MB</td> </tr> </tbody> </table> <p>Default for APSIZE[5:0]=000000b forces default APBASE[27:22] =000000b (i.e., all bits respond as “hardwired” to 0). This provides maximum aperture size of 256 MB. As another example, programming APSIZE[5:0]=111000b hardwires APBASE[24:22]=000b and while enabling APBASE[27:25] as read/write.</p>	5	4	3	2	1	0	Aperture Size	1	1	1	1	1	1	4 MB	1	1	1	1	1	0	8 MB	1	1	1	1	0	0	16 MB	1	1	1	0	0	0	32 MB	1	1	0	0	0	0	64 MB	1	0	0	0	0	0	128 MB	0	0	0	0	0	0	256 MB
5	4	3	2	1	0	Aperture Size																																																			
1	1	1	1	1	1	4 MB																																																			
1	1	1	1	1	0	8 MB																																																			
1	1	1	1	0	0	16 MB																																																			
1	1	1	0	0	0	32 MB																																																			
1	1	0	0	0	0	64 MB																																																			
1	0	0	0	0	0	128 MB																																																			
0	0	0	0	0	0	256 MB																																																			

3.5.30 ATTBASE—Aperture Translation Table Base Register (Device 0)

Address Offset:	B8–BBh
Default Value:	0000_0000h
Access:	R/W
Size:	32 bits

This register provides the starting address of the Graphics Aperture Translation Table Base located in the system memory. This value is used by the MCH Graphics Aperture address translation logic (including the GTLB logic) to obtain the appropriate address translation entry required during the translation of the aperture address into a corresponding physical system memory address. The ATTBASE register may be dynamically changed.

Note: The address provided via ATTBASE is 4 KB aligned.

Bit	Description
31:12	<p>Aperture Translation Table Base (TTABLE). This field contains a pointer to the base of the translation table used to map memory space addresses in the aperture range to addresses in system memory.</p> <p>Note: It should be modified only when the GTLB has been disabled.</p>
11:0	Reserved.

3.5.31 AMTT—AGP Interface Multi-Transaction Timer Register (Device 0)

Address Offset:	BCh
Default Value:	00h
Access:	R/W
Size:	8 bits

AMTT is an 8-bit register that controls the amount of time that the MCH arbiter allows AGP master to perform multiple back-to-back transactions. The MCH AMTT mechanism is used to optimize the performance of the AGP master (using PCI protocol) that performs multiple back-to-back transactions to fragmented memory ranges (and as a consequence it can not use long burst transfers). The AMTT mechanism applies to the host-AGP transactions as well and it guarantees to the processor a fair share of the AGP interface bandwidth.

The number of clocks programmed in the AMTT represents the guaranteed time slice (measured in 66 MHz clocks) allotted to the current agent (either AGP master or host bridge) after which the AGP arbiter will grant the bus to another agent. The default value of AMTT is 00h and disables this function. The AMTT value can be programmed with 8-clock granularity. For example, if the AMTT is programmed to 18h, then the selected value corresponds to the time period of 24 AGP (66 MHz) clocks.

Bit	Description
7:3	Multi-Transaction Timer Count Value (MTTC). The number programmed in these bits represents the guaranteed time slice (measured in eight 66 MHz clock granularity) allotted to the current agent (either AGP master or MCH) after which the AGP arbiter will grant the bus to another agent.
2:0	Reserved.

3.5.32 LPTT—AGP Low Priority Transaction Timer Register (Device 0)

Address Offset:	BDh
Default Value:	00h
Access:	R/W
Size:	8 bits

LPTT is an 8-bit register similar in function to AMTT. This register is used to control the minimum tenure on the AGP for low-priority data transactions (both reads and writes) issued using PIPE# or SB mechanisms.

The number of clocks programmed in the LPTT represents the guaranteed time slice (measured in 66 MHz clocks) allotted to the current low priority AGP transaction data transfer state. This does not necessarily apply to a single transaction but it can span over multiple low-priority transactions of the same type. After this time expires, the AGP arbiter may grant the bus to another agent if there is a pending request. The LPTT does not apply in the case of high-priority request where ownership is transferred directly to high-priority requesting queue. The default value of LPTT is 00h and disables this function. The LPTT value can be programmed with 8-clock granularity. For example, if the LPTT is programmed to 10h, the selected value corresponds to the time period of 16 AGP (66 MHz) clocks.

Bit	Description
7:3	Low Priority Transaction Timer Count Value (LPTTC). The number of clocks programmed in these bits represents the guaranteed time slice (measured in eight 66 MHz clock granularity) allotted to the current low priority AGP transaction data transfer state.
2:0	Reserved.

3.5.33 TOM—Top of Low Memory Register (Device 0)

Address Offset:	C4–C5h
Default Value:	0100h
Access:	R/W
Size:	16 bits

This register contains the maximum address below 4 GB that should be treated as a memory access. Note that this register must be set to a value of 0100h (16 MB) or greater. Usually it will sit below the areas configured for the hub interface, PCI memory, and the graphics aperture.

Bit	Description
15:4	<p>Top of Low Memory (TOM). This register contains the address that corresponds to bits 31 to 20 of the maximum system memory address that lies below 4 GB. Configuration software should set this value to either the maximum amount of memory in the system or to the minimum address allocated for PCI memory or the graphics aperture, whichever is smaller.</p> <p>Programming Example: 400h = 1 GB. An access to 4000_0000h or above will be considered above the TOM and therefore not routed to system memory. It may go to AGP, aperture, or subtractively decode to the hub interface.</p>
3:0	Reserved.

3.5.34 MCHCFG—MCH Configuration Register (Device 0)

Offset: C6–C7h
 Default: 0000h
 Access: R/W, RO
 Size: 16 bits

Bit	Description
15:12	Reserved.
11	<p>System Memory Frequency Select. This bit must be programmed prior to memory initialization.</p> <p>0 = Reserved</p> <p>1 = System Memory frequency is set to 133 MHz</p>
11:6	Reserved.
5	<p>MDA Present (MDAP)—R/W. This bit works with the VGA Enable bit in the BCTRL1 register (device 1) to control the routing of host-initiated transactions targeting MDA compatible I/O and memory address ranges. This bit should not be set when the VGA Enable bit is not set in either device 1. If the VGA enable bit is set, then accesses to I/O address range x3BCh–x3BFh are forwarded to the hub interface. MDA resources are defined as the following:</p> <p>Memory: 0B0000h–0B7FFFh</p> <p>I/O: 3B4h, 3B5h, 3B8h, 3B9h, 3BAh, 3BFh, (including ISA address aliases, A[15:10] are not used in decode)</p> <p>Any I/O reference that includes the I/O locations listed above, or their aliases, are forwarded to the hub interface, even if the reference includes I/O locations not listed above.</p> <p>Refer to the Chapter 4 for further information.</p>
4:3	Reserved.
2	<p>In-Order Queue Depth (IOQD)—RO. This bit reflects the value sampled on HA7# on the deassertion of the CPURST#. It indicates the depth of the host bus in-order queue (i.e., level of host bus pipelining).</p> <p>0 = HA7# was sampled asserted (i.e., 0); the depth of the host bus in-order queue is set to 1 (i.e., no pipelining support on the host bus).</p> <p>1 = HA7# was sampled 1 (i.e., undriven on the host bus); the depth of the host bus in-order queue is configured to the maximum allowed by the host bus protocol (i.e., 12). Note that the MCH has a 12 deep IOQ.</p> <p>Note that HA7# is not driven by the MCH during CPURST#. If an IOQ size of 1 is desired, HA7# must be driven low during CPURST# by an external source.</p>
1	<p>APIC Memory Range Disable (APICDIS)—R/W.</p> <p>0 = The MCH sends cycles between 0_FEC0_0000 and 0_FEC7_FFFF to the hub interface.</p> <p>1 = The MCH forwards accesses to the IOAPIC regions to the appropriate interface, as specified by the memory and PCI configuration registers.</p>
0	Reserved.

3.5.35 ERRSTS—Error Status Register (Device 0)

Address Offset:	C8–C9h
Default Value:	0000h
Access:	R/WC
Size:	16 bits

This register is used to report various error conditions via the hub interface messages to ICH2. An SERR, SMI, or SCI error message may be generated via the hub interface on a zero to one transition of any of these flags when enabled in the PCICMD/ERRCMD, SMICMD, or SCICMD registers, respectively. These bits are set, regardless of whether or not the SERR is enabled and generated.

Bit	Description
15:10	Reserved.
9	LOCK to non-DRAM Memory Flag (LCKF). 0 =Software must write a 1 to clear this status bit. 1 =Indicates that a host initiated LOCK cycle targeting non-DRAM memory space occurred.
8:7	Reserved.
6	SERR on Hub Interface Target Abort (TAHLA). 0 =Software must write a 1 to clear this status bit. 1 =MCH detected that a MCH-originated hub interface cycle was terminated with a Target Abort completion packet or special cycle.
5	MCH Detects Unimplemented Hub Interface Special Cycle (HIAUSC). 0 =Software must write a 1 to clear this status bit. 1 =MCH detected an Unimplemented Special Cycle on the hub interface.
4	AGP Access Outside of Graphics Aperture Flag (OOGF). 0 =Software must write a 1 to clear this status bit. 1 =Indicates that an AGP access occurred to an address that is outside of the graphics aperture range.
3	Invalid AGP Access Flag (IAAF). 0 =Software must write a 1 to clear this status bit. 1 =Indicates that an AGP access was attempted outside of the graphics aperture and either to the 640 KB – 1 MB range or above the top of memory.
2	Invalid Graphics Aperture Translation Table Entry (ITTEF). 0 =Software must write a 1 to clear this status bit. 1 =Indicates that an invalid translation table entry was returned in response to an AGP access to the graphics aperture.
1	Multiple-bit DRAM ECC Error Flag (DMERR). 0 =After software completes the error processing, a value of 1 is written to this bit field to set the value back to 0 and unlock the error logging mechanism. 1 =A memory read data transfer had an uncorrectable multiple-bit error. When this bit is set, the address and device number that caused the error are logged in the EAP Register. Software uses bits [1:0] to detect whether the logged error address is for Single or Multiple-bit error.

Bit	Description
0	<p>Single-bit DRAM ECC Error Flag (DSERR).</p> <p>0 = Software must write a 1 to clear this bit and unlock the error logging mechanism.</p> <p>1 = A memory read data transfer had a single-bit correctable error and the corrected data was sent for the access. When this bit is set, the address, channel number, and device number that caused the error are logged in the EAP Register. When this bit is set, the EAP, CN, DN, and ES fields are locked to further single bit error updates until the processor clears this bit by writing a 1.</p>

3.5.36 ERRCMD—Error Command Register (Device 0)

Address Offset:	CA–CBh
Default Value:	0000h
Access:	R/W
Size:	16 bits

This register enables various errors to generate a SERR message via the hub interface. Since the MCH does not have an SERR# signal, SERR messages are passed from the MCH to the ICH2 over the hub interface. When a bit in this register is set, a SERR message will be generated on the hub interface when the corresponding flag is set in the ERRSTS register. The actual generation of the SERR message is globally enabled for Device 0 via the PCICMD register.

Note: An error can generate one and only one error message via the hub interface. It is software's responsibility to make sure that when an SERR error message is enabled for an error condition, SMI and SCI error messages are disabled for that same error condition.

Bit	Description
15:10	Reserved.
9	<p>SERR on Non-DRAM Lock (LCKERR).</p> <p>0 = Disable.</p> <p>1 = Enable. The MCH will generate a hub interface SERR special cycle when a processor lock cycle is detected that does not hit system memory.</p>
8:7	Reserved.
6	<p>SERR on Target Abort on Hub Interface Exception (TAHLA_SERR).</p> <p>0 = Disable.</p> <p>1 = Enable. Generation of the hub interface SERR message is enabled when a MCH-originated hub interface cycle is completed with "Target Abort" completion packet or special cycle status.</p>
5	<p>SERR on Detecting Hub Interface Unimplemented Special Cycle (HIAUSCERR). SERR messaging for Device 0 is globally enabled in the PCICMD register.</p> <p>0 = Disable. MCH does not generate an SERR message for this event.</p> <p>1 = Enable. MCH generates a SERR message over the hub interface when an unimplemented Special Cycle is received on the hub interface.</p>

Bit	Description
4	<p>SERR on AGP Access Outside of Graphics Aperture (OOGF_SERR).</p> <p>0 = Disable.</p> <p>1 = Enable. Generation of the hub interface SERR message is enabled when an AGP access occurs to an address outside of the graphics aperture.</p>
3	<p>SERR on Invalid AGP Access (IAAF_SERR).</p> <p>0 = Disable.</p> <p>1 = Generation of the hub interface SERR message is enabled when an AGP access occurs to an address outside of the graphics aperture and either to the 640 KB – 1 MB range or above the top of memory.</p>
2	<p>SERR on Invalid Translation Table Entry (ITTEF_SERR).</p> <p>0 = Disable.</p> <p>1 = Enable. Generation of the hub interface SERR message is enabled when an invalid translation table entry was returned in response to an AGP access to the graphics aperture.</p>
1	<p>SERR Multiple-Bit DRAM ECC Error (DMERR_SERR).</p> <p>0 = Disable. For systems not supporting ECC, this bit must be disabled.</p> <p>1 = Enable. Generation of the hub interface SERR message is enabled when the MCH system memory controller detects a multiple-bit error.</p>
0	<p>SERR on Single-bit ECC Error (DSERR).</p> <p>0 = Disable. For systems that do not support ECC, this bit must be disabled.</p> <p>1 = Enable. Generation of the hub interface SERR message is enabled when the MCH system memory controller detects a single bit error.</p>

3.5.37 SMICMD—SMI Command Register (Device 0)

Address Offset:	CC–CDh
Default Value:	0000h
Access:	R/W
Size:	16 bits

This register enables various errors to generate a SMI message via the hub interface.

Note: An error can generate one and only one error message via the hub interface. It is software's responsibility to make sure that when an SMI error message is enabled for an error condition, SERR and SCI error messages are disabled for that same error condition.

Bit	Description
15:2	Reserved.
1	<p>SMI on Multiple-Bit DRAM ECC Error (DMERR).</p> <p>0 =Disable. For systems not supporting ECC, this bit must be disabled.</p> <p>1 =Enable. Generation of the hub interface SMI message is enabled when the MCH system memory controller detects a multiple-bit error.</p>
0	<p>SMI on Single-bit ECC Error (DSERR).</p> <p>0 =Disable. For systems that do not support ECC, this bit must be disabled.</p> <p>1 =Enable. Generation of the hub interface SMI message is enabled when the MCH system memory controller detects a single bit error.</p>

3.5.38 SCICMD—SCI Command Register (Device 0)

Address Offset:	CE–CDh
Default Value:	0000h
Access:	R/W
Size:	16 bits

This register enables various errors to generate a SCI message via the hub interface.

Note: An error can generate one and only one error message via the hub interface. It is software's responsibility to make sure that when an SCI error message is enabled for an error condition, SERR and SMI error messages are disabled for that same error condition.

Bit	Description
15:2	Reserved.
1	<p>SCI on Multiple-Bit DRAM ECC Error (DMERR).</p> <p>0 =Disable. For systems not supporting ECC, this bit must be disabled.</p> <p>1 =Enable. Generation of the hub interface SCI message is enabled when the MCH system memory controller detects a multiple-bit error.</p>
0	<p>SCI on Single-bit ECC Error (DSERR).</p> <p>0 =Disable. For systems that do not support ECC, this bit must be disabled.</p> <p>1 =Enable. Generation of the hub interface SCI message is enabled when the MCH system memory controller detects a single bit error.</p>

3.5.39 SKPD—Scratchpad Data Register (Device 0)

Address Offset: DE–DFh
 Default Value: 0000h
 Access: R/W
 Size: 16 bits

Bit	Description
15:0	Scratchpad [15:0]. These bits are R/W storage bits that have no effect on the MCH functionality.

3.5.40 CAPID—Product Specific Capability Identifier Register (Device 0)

Address Offset: E4h
 Default Value: 0104A009h
 Access: RO
 Size: 32 bits

Bit	Descriptions
31	System Memory Capability. 0 = Component only supports SDR SDRAM memory; DRAM Type field is read-only. (default) 1 = Reserved
30	Mobile Power Management Capability. 0 = Component is NOT capable of all mobile power management features and is limited to desktop use only (default) 1 = Component is capable of all mobile power management features.
29:28	Reserved.
27:24	CAPID Version. 0001b = First revision of the CAPID register definition. (default)
23:16	CAPID Length. 04h = Indicates a structure length of 4 bytes. (default)
15:8	Next Capability Pointer. A0h = Points to the next Capability ID in this device (ACAPID register). (default)
7:0	CAP_ID. 1001b = Identifies the CAP_ID assigned by the PCI SIG for vendor dependent capability pointers. (default)

3.6 Bridge Registers (Device 1)

Table 10. provides the register address map for Device 0 PCI configuration space. An “s” in the Default Value column indicates that a strap determines the power-up default value for that bit.

Table 10. Intel® MCH Configuration Space (Device 1)

Address Offset	Symbol	Name	Default	Access
00-01h	VID1	Vendor Identification	8086h	RO
02-03h	DID1	Device Identification	1A31h	RO
04-05h	PCICMD1	PCI Command	0000h	RO, R/W
06-07h	PCISTS1	PCI Status	00A0h	RO, R/WC
08	RID1	Revision Identification	03h, 04h	RO
09	—	Reserved	—	—
0Ah	SUBC1	Sub-Class Code	04h	RO
0Bh	BCC1	Base Class Code	06h	RO
0Ch	—	Reserved	—	—
0Dh	MLT1	Master Latency Timer	00h	R/W
0Eh	HDR1	Header Type	01h	RO
0F-17h	—	Reserved	—	—
18h	PBUSN1	Primary Bus Number	00h	RO
19h	SBUSN1	Secondary Bus Number	00h	R/W
1Ah	SUBUSN1	Subordinate Bus Number	00h	R/W
1Bh	SMLT1	Secondary Bus Master Latency Timer	00h	R/W
1Ch	IOBASE1	I/O Base Address	F0h	R/W
1Dh	IOLIMIT1	I/O Limit Address	00h	R/W
1E-1Fh	SSTS1	Secondary Status	02A0h	RO, R/WC
20-21h	MBASE1	Memory Base Address	FFF0h	R/W
22-23h	MLIMIT1	Memory Limit Address	0000h	R/W
24-25h	PMBASE1	Prefetchable Memory Base Address	FFF0h	R/W
26-27h	PMLIMIT1	Prefetchable Memory Limit Address	0000h	R/W
28-3Dh	—	Reserved	—	—
3Eh	BCTRL1	Bridge Control	00h	RO, R/W
3Fh	—	Reserved	—	—
40h	ERRCMD1	Error Command	00h	R/W
41-4Fh	—	Reserved	—	—
50-57h	DWTC	DRAM Write Thermal Management Control	00000000h	R/W/L

Address Offset	Symbol	Name	Default	Access
58–5Fh	DRTC	DRAM Read Thermal Management Control	00000000h	R/W/L
59–FFh	—	Reserved	—	—

3.6.1 VID1—Vendor Identification Register (Device 1)

Address Offset:	00–01h
Default Value:	8086h
Attribute:	RO
Size:	16 bits

The VID1 register contains the vendor identification number. This 16-bit register combined with the DID1 Register uniquely identifies any PCI device. Writes to this register have no effect.

Bit	Description
15:0	Vendor Identification Number. This is a 16-bit value assigned to Intel. Intel VID = 8086h.

3.6.2 DID1—Device Identification Register (Device 1)

Address Offset:	02–03h
Default Value:	1A31h
Attribute:	RO
Size:	16 bits

This 16-bit register combined with the VID1 register uniquely identifies any PCI device. Writes to this register have no effect.

Bit	Description
15:0	Device Identification Number. This is a 16-bit value assigned to the MCH Device 1. MCH1 Device 1 DID = 1A31h.

3.6.3 PCICMD1—PCI-PCI Command Register (Device 1)

Address Offset: 04–05h
 Default: 0000h
 Access: RO, R/W
 Size: 16 bits

Bit	Descriptions
15:10	Reserved.
9	Fast Back-to-Back (FB2B)—RO. Not Implemented; Hardwired to 0.
8	<p>SERR Message Enable (SERRE1)—R/W. This bit is a global enable bit for Device 1 SERR messaging. The MCH does not have an SERR# signal. The MCH communicates the SERR# condition by sending an SERR message to the ICH2.</p> <p>0 = Disable. SERR message is not generated by the MCH for Device 1.</p> <p>1 = Enable. MCH is enabled to generate SERR messages over the hub interface for specific Device 1 error conditions that are individually enabled in the BCTRL register. The error status is reported in the PCISTS1 register.</p> <p>NOTE: This bit only controls SERR messaging for the Device 1. Device 0 has its own SERRE bit to control error reporting for error conditions occurring on Device 0.</p>
7	Address/Data Stepping (ADSTEP)—RO. Not Implemented; Hardwired to 0.
6	Parity Error Enable (PERRE1)—RO. Not Implemented; Hardwired to 0.
5	Reserved.
4	Memory Write and Invalidate Enable (MWIE)—RO. Not Implemented; Hardwired to 0.
3	Special Cycle Enable (SCE)—RO. Not Implemented; Hardwired to 0.
2	Bus Master Enable (BME1)—R/W. This bit is not functional. It is a R/W bit for compatibility with compliance testing software.
1	<p>Memory Access Enable (MAE1)—R/W.</p> <p>0 = Disable. All of Device 1's memory space is disabled.</p> <p>1 = Enable. The Memory and Prefetchable memory address ranges defined in the MBASE1, MLIMIT1, PMBASE1, and PMLIMIT1 registers are enabled.</p>
0	<p>I/O Access Enable (IOAE1)—R/W.</p> <p>0 = Disable. All of device 1's I/O space is disabled.</p> <p>1 = Enable. This bit must be set to 1 to enable the I/O address range defined in the IOBASE1, and IOLIMIT1 registers.</p>

3.6.4 PCISTS1—PCI-PCI Status Register (Device 1)

Address Offset:	06–07h
Default Value:	00A0h
Access:	RO, R/WC
Size:	16 bits

PCISTS1 is a 16-bit status register that reports the occurrence of error conditions associated with primary side of the “virtual” PCI-PCI bridge embedded in the MCH. Since this device does not physically reside on PCI_A, it reports the optimum operating conditions so that it does not restrict the capability of PCI_A.

Bit	Descriptions
15	Detected Parity Error (DPE1)—RO. Not Implemented; Hardwired to 0.
14	Signaled System Error (SSE1)—R/WC. 0 =Software clears this bit by writing a 1 to it. 1 =MCH device 1 generated an SERR message over the hub interface for any enabled Device 1 error condition. Device 1 error conditions are enabled in the ERRCMD, PCICMD1 and BCTRL1 registers. Device 1 error flags are read/reset from the ERRSTS and SSTS1 register.
13	Received Master Abort Status (RMAS1)—RO. Not Implemented; Hardwired to 0.
12	Received Target Abort Status (RTAS1)—RO. Not Implemented; Hardwired to 0.
11	Signaled Target Abort Status (STAS1)—RO. Not Implemented; Hardwired to 0.
10:9	DEVSEL# Timing (DEVT1)—RO. Hardwired to 00b. Indicate that the device 1 uses the fastest possible decode.
8	Data Parity Detected (DPD1). Not Implemented; Hardwired to 0.
7	Fast Back-to-Back (FB2B1)—RO. Hardwired to 1. The AGP port always supports fast back to back transactions.
6	Reserved.
5	66 MHz Capability (CAP66)—RO. Hardwired to 1. Indicates that the AGP port is 66 MHz capable.
4:0	Reserved.

3.6.5 RID1—Revision Identification Register (Device 1)

Address Offset:	08h
Default Value:	See RID1 table below
Access:	RO
Size:	8 bits

This register contains the revision number of the MCH device 1. These bits are read only and writes to this register have no effect.

Bit	Description
7:0	<p>Revision Identification Number (RID): This is an 8-bit value that indicates the revision identification number for the MCH device 1.</p> <p>03h = A3 Stepping</p> <p>04h = B0 Stepping</p>

3.6.6 SUBC1—Sub-Class Code Register (Device 1)

Address Offset:	0Ah
Default Value:	04h
Access:	RO
Size:	8 bits

This register contains the Sub-Class Code for the MCH device 1.

Bit	Description
7:0	<p>Sub-Class Code (SUBC1): This is an 8-bit value that indicates the category of bridge of the MCH.</p> <p>04h = Host bridge.</p>

3.6.7 BCC1—Base Class Code Register (Device 1)

Address Offset:	0Bh
Default Value:	06h
Access:	RO
Size:	8 bits

This register contains the Base Class Code of the MCH device 1.

Bit	Description
7:0	<p>Base Class Code (BASEC): This is an 8-bit value that indicates the Base Class Code for the MCH device 1.</p> <p>06h = Bridge device.</p>

3.6.8 MLT1—Master Latency Timer Register (Device 1)

Address Offset:	0Dh
Default Value:	00h
Access:	R/W
Size:	8 bits

This functionality is not applicable. It is described here since these bits should be implemented as a read/write to prevent standard PCI-PCI bridge configuration software from getting “confused”.

Bit	Description
7:3	Not applicable but supports read/write operations. (Reads return previously written data.)
2:0	Reserved.

3.6.9 HDR1—Header Type Register (Device 1)

Offset:	0Eh
Default:	01h
Access:	RO
Size:	8 bits

This register identifies the header layout of the configuration space.

Bit	Descriptions
7:0	This read only field always returns 01h when read. Writes have no effect.

3.6.10 PBUSN1—Primary Bus Number Register (Device 1)

Offset:	18h
Default:	00h
Access:	RO
Size:	8 bits

This register identifies that “virtual” PCI-PCI Bridge is connected to bus #0.

Bit	Descriptions
7:0	Bus Number. Hardwired to 0.



3.6.11 SBUSN1—Secondary Bus Number Register (Device 1)

Offset: 19h
 Default: 00h
 Access: R/W
 Size: 8 bits

This register identifies the bus number assigned to the second bus side of the “virtual” PCI-PCI bridge i.e. to AGP. This number is programmed by the PCI configuration software to allow mapping of configuration cycles to AGP.

Bit	Descriptions
7:0	Bus Number. Programmable. Default = 00h.

3.6.12 SUBUSN1—Subordinate Bus Number Register (Device 1)

Offset: 1Ah
 Default: 00h
 Access: R/W
 Size: 8 bits

This register identifies the subordinate bus (if any) that resides at the level below AGP. This number is programmed by the PCI configuration software to allow mapping of configuration cycles to AGP.

Bit	Descriptions
7:0	Bus Number. Programmable. Default = 0.

3.6.13 SMLT1—Secondary Master Latency Timer Register (Device 1)

Address Offset:	1Bh
Default Value:	00h
Access:	R/W
Size:	8 bits

This register controls the bus tenure of the MCH on AGP. MLT is an 8-bit register that controls the amount of time the MCH, as an AGP/PCI bus master, can burst data on the AGP bus. The count value is an 8-bit quantity; however, MLT[2:0] are reserved and have a value of 0 when determining the count value. The MCH's MLT is used to guarantee to the AGP master a minimum amount of the system resources. When the MCH begins the first AGP FRAME# cycle after being granted the bus, the counter is loaded and enabled to count from the assertion of FRAME#. If the count expires while the MCH's grant is removed (due to AGP master request), the MCH will lose the use of the bus, and the AGP master agent may be granted the bus. If the MCH's bus grant is not removed, the MCH continues to own the AGP bus, regardless of the MLT expiration or idle condition. Note that the MCH always properly terminates an AGP transaction, with FRAME# negation prior to the final data transfer.

The number of clocks programmed in the MLT represents the guaranteed time slice (measured in 66 MHz AGP clocks) allotted to the MCH, after which it must complete the current data transfer phase and then surrender the bus as soon as its bus grant is removed. For example, if the MLT is programmed to 18h, the value is 24 AGP clocks. The default value of MLT is 00h and disables this function. When the MLT is disabled, the burst time for the MCH is unlimited (i.e., the MCH can burst forever).

Bit	Description
7:3	Secondary MLT Counter Value. Default=0s (i.e., SMLT disabled)
2:0	Reserved.

3.6.14 IOBASE1—I/O Base Address Register (Device 1)

Address Offset:	1Ch
Default Value:	F0h
Access:	R/W
Size:	8 bits

This register controls the hosts to AGP I/O access routing based on the following formula:

$$\text{IO_BASE} \leq \text{address} \leq \text{IO_LIMIT}$$

Only upper 4 bits are programmable. For the purpose of address decode, address bits A[11:0] are treated as 0. Thus, the bottom of the defined I/O address range is aligned to a 4 KB boundary.

Bit	Description
7:4	I/O Address Base. Corresponds to A[15:12] of the I/O address. (Default=F0h)
3:0	Reserved.

3.6.15 IOLIMIT1—I/O Limit Address Register (Device 1)

Address Offset:	1Dh
Default Value:	00h
Access:	R/W
Size:	8 bits

This register controls the hosts to AGP I/O access routing based on the following formula:

$$\text{IO_BASE} \leq \text{address} \leq \text{IO_LIMIT}$$

Only upper 4 bits are programmable. For the purpose of address decode, address bits A[11:0] are assumed to be FFFh. Thus, the top of the defined I/O address range is at the top of a 4 KB aligned address block.

Bit	Description
7:4	I/O Address Limit. Corresponds to A[15:12] of the I/O address. (Default=0)
3:0	Reserved. (Only 16-bit addressing supported.)

3.6.16 SSTS1—Secondary PCI-PCI Status Register (Device 1)

Address Offset:	1E–1Fh
Default Value:	02A0h
Access:	RO, R/WC
Size:	16 bits

SSTS1 is a 16-bit status register that reports the occurrence of error conditions associated with secondary side (i.e., AGP side) of the “virtual” PCI-PCI bridge embedded in the MCH.

Bit	Descriptions
15	Detected Parity Error (DPE1)—R/WC. 0 = Software sets this bit to 0 by writing a 1 to it. 1 = MCH detected a parity error in the address or data phase of AGP bus transactions.
14	Reserved.
13	Received Master Abort Status (RMAS1)—R/WC. 0 = Software sets this bit to 0 by writing a 1 to it. 1 = MCH terminated a Host-to-AGP with an unexpected master abort.
12	Received Target Abort Status (RTAS1)—R/WC. 0 = Software sets this bit to 0 by writing a 1 to it. 1 = MCH-initiated transaction on AGP is terminated with a target abort.
11	Signaled Target Abort Status (STAS1)—RO. Hardwired to a 0. The MCH does not generate target abort on AGP.
10:9	DEVSEL# Timing (DEVT1)—RO. Hardwired to 01. This 2-bit field indicates the timing of the DEVSEL# signal when the MCH responds as a target on AGP. This field indicates the time when a valid DEVSEL# can be sampled by the initiator of the PCI cycle. 01 = Medium timing.
8	Master Data Parity Error Detected (DPD1)—RO. Hardwired to 0. MCH does not implement G_PERR# signal.
7	Fast Back-to-Back (FB2B1)—RO. Hardwired to 1. MCH as a target supports fast back-to-back transactions on AGP.
6	Reserved.
5	66 MHz Capable (CAP66)—RO. Hardwired to 1. AGP bus is capable of 66 MHz operation.
4:0	Reserved.

3.6.17 MBASE1—Memory Base Address Register (Device 1)

Address Offset:	20–21h
Default Value:	FFF0h
Access:	R/W
Size:	16 bits

This register controls the host to AGP non-prefetchable memory accesses routing based on the following formula:

$$\text{MEMORY_BASE1} \leq \text{address} \leq \text{MEMORY_LIMIT1}$$

The upper 12 bits of the register are read/write and correspond to the upper 12 address bits A[31:20] of the 32-bit address. The bottom 4 bits of this register are read-only and return 0s when read. The configuration software must initialize this register. For the purpose of address decode, address bits A[19:0] are assumed to be 0. Thus, the bottom of the defined memory address range will be aligned to a 1 MB boundary.

Bit	Description
15:4	Memory Address Base 1 (MEM_BASE1) . Corresponds to A[31:20] of the memory address.
3:0	Reserved.

3.6.18 MLIMIT1—Memory Limit Address Register (Device 1)

Address Offset:	22–23h
Default Value:	0000h
Access:	R/W
Size:	16 bits

This register controls the host to AGP non-prefetchable memory accesses routing based on the following formula:

$$\text{MEMORY_BASE1} \leq \text{address} \leq \text{MEMORY_LIMIT1}$$

The upper 12 bits of the register are read/write and correspond to the upper 12 address bits A[31:20] of the 32-bit address. The bottom 4 bits of this register are read-only and return 0s when read. The configuration software must initialize this register. For the purpose of address decode, address bits A[19:0] are assumed to be FFFFh. Thus, the top of the defined memory address range will be at the top of a 1 MB aligned memory block.

Bit	Description
15:4	Memory Address Limit 1 (MEM_LIMIT1) . Corresponds to A[31:20] of the memory address. Default=0
3:0	Reserved.

Note: Memory range covered by MBASE1 and MLIMIT1 registers are used to map non-prefetchable AGP address ranges (typically, where control/status memory-mapped I/O data structures of the graphics controller will reside) and PMBASE 1 and PMLIMIT1 Registers are used to map prefetchable address ranges (typically, graphics local memory). This segregation allows application of USWC space attributes to be performed in a true plug-and-play manner to the prefetchable address range for improved host-AGP memory access performance.

3.6.19 PMBASE1—Prefetchable Memory Base Address Register (Device 1)

Address Offset:	24–25h
Default Value:	FFF0h
Access:	R/W
Size:	16 bits

This register controls the host to AGP prefetchable memory accesses routing based on the following formula:

$$\text{PREFETCHABLE_MEMORY_BASE1} \leq \text{address} \leq \text{PREFETCHABLE_MEMORY_LIMIT1}$$

The upper 12 bits of the register are read/write and correspond to the upper 12 address bits A[31:20] of the 32-bit address. The bottom 4 bits of this register are read-only and return 0s when read. The configuration software must initialize this register. For the purpose of address decode, address bits A[19:0] are assumed to be 0. Thus, the bottom of the defined memory address range will be aligned to a 1 MB boundary.

Bit	Description
15:4	Prefetchable Memory Address Base 1 (PMEM_BASE1) . Corresponds to A[31:20] of the memory address.
3:0	Reserved.

3.6.20 PMLIMIT1—Prefetchable Memory Limit Address Register (Device 1)

Address Offset:	26–27h
Default Value:	0000h
Access:	R/W
Size:	16 bits

This register controls the host to AGP prefetchable memory accesses routing based on the following formula:

$$\text{PREFETCHABLE_MEMORY_BASE1} \leq \text{address} \leq \text{PREFETCHABLE_MEMORY_LIMIT1}$$

The upper 12 bits of the register are read/write and correspond to the upper 12 address bits A[31:20] of the 32-bit address. The bottom 4 bits of this register are read-only and return 0s when read. The configuration software must initialize this register. For the purpose of address decode, address bits A[19:0] are assumed to be FFFFh. Thus, the top of the defined memory address range will be at the top of a 1 MB aligned memory block.

Bit	Description
15:4	Prefetchable Memory Address Limit 1 (PMEM_LIMIT1) . Corresponds to A[31:20] of the memory address. (Default=00h)
3:0	Reserved.

Note: Prefetchable memory range is supported to allow segregation by the configuration software between the memory ranges that must be defined as UC and the ones that can be designated as a USWC (i.e., prefetchable) from the processor perspective.

3.6.21 BCTRL1—PCI-PCI Bridge Control Register (Device 1)

Address Offset:	3Eh
Default:	00h
Access:	RO, R/W
Size	8 bits

This register provides extensions to the PCICMD1 register that are specific to PCI-PCI bridges. BCTRL1 provides additional control for the secondary interface (i.e., AGP) as well as some bits that affect the overall behavior of the “virtual” PCI-PCI bridge embedded in the MCH (e.g., VGA compatible address ranges mapping).

Bit	Descriptions
7	Fast Back to Back Enable (FB2BEN)—RO. Hardwired to 0. Since there is only one target allowed on AGP, this bit is meaningless. The MCH will not generate FB2B cycles in 1x mode, but will generate FB2B cycles in 2x and 4x Fast Write modes.
6	Secondary Bus Reset (SRESET)—RO. Hardwired to 0. MCH does not support generation of reset via this bit on the AGP. Note: The only way to perform a hard reset of the AGP is via the system reset either initiated by software or hardware via the ICH2.
5	Master Abort Mode (MAMODE)—RO. Hardwired to 0. This means that when acting as a master on AGP and a Master Abort occurs, the MCH will discard data on writes and return all 1s during reads.
4	Reserved.
3	VGA Enable (VGA_EN1)—R/W. This bit controls the routing of host-initiated transactions targeting VGA compatible I/O and memory address ranges. 0 =VGA compatible memory and I/O range accesses are not forwarded to AGP (Default). Rather, they are mapped to primary PCI unless they are mapped to AGP via I/O and memory range registers defined above (IOBASE1, IOLIMIT1, MBASE1, MLIMIT1, PMBASE1, PMLIMIT1) 1 =MCH forwards the following host accesses to the AGP: <ul style="list-style-type: none"> • Memory accesses in the range 0A0000h to 0BFFFFh • I/O addresses where A[9:0] are in the ranges 3B0h to 3BBh and 3C0h to 3DFh (inclusive of ISA address aliases - A[15:10] are not decoded) When this bit is set, forwarding of these accesses issued by the host is independent of the I/O address and memory address ranges defined by the previously defined base and limit registers. Forwarding of these accesses is also independent of the settings of bit 2 (ISA Enable) of this register if this bit is 1. Refer to Chapter 4 for further information.
2	ISA Enable (ISA_EN)—R/W. Modifies the response by the MCH to an I/O access issued by the host that targets ISA I/O addresses. This applies only to I/O addresses that are enabled by the IOBASE and IOLIMIT registers. 0 =Disable. All addresses defined by the IOBASE and IOLIMIT Registers for host I/O transactions are mapped to AGP (Default). 1 =Enable. MCH does not forward to AGP any I/O transactions addressing the last 768 bytes in each 1 KB block, even if the addresses are within the range defined by the IOBASE and IOLIMIT registers. Instead of going to AGP, these cycles are forwarded to PCI0 where they can be subtractively or positively claimed by the ISA bridge.
1	Reserved.

Bit	Descriptions
0	<p>Parity Error Response Enable (PER_EN)—R/W. Controls MCH's response to data phase parity errors on AGP.</p> <p>0 =Address and data parity errors on AGP are not reported via the MCH hub interface SERR# messaging mechanism. Other types of error conditions can still be signaled via SERR# messaging independent of this bit's state.</p> <p>1 =The G_PERR# signal is not implemented by the MCH. However, when this bit is set to 1, address and data parity errors detected on AGP are reported via hub interface SERR# messaging mechanism, if further enabled by SERRE1.</p>

3.6.22 ERRCMD1—Error Command Register (Device 1)

Address Offset: 40h
 Default Value: 00h
 Access: R/W
 Size: 8 bits

Bit	Description
7:1	Reserved.
0	<p>SERR on Receiving Target Abort (SERTA).</p> <p>0 =MCH does not assert an SERR message upon receipt of a target abort on AGP. SERR messaging for Device 1 is globally enabled in the PCICMD1 register.</p> <p>1 =MCH generates an SERR message over the hub interface when a target abort is received on AGP.</p>

3.6.23 DWTC—DRAM Write Thermal Management Control Register (Device 1)

Address Offset: 50–57h
 Default Value: 00h
 Access: R/W/L
 Size: 64 bits

Bit	Descriptions
63:41	Reserved.
40:28	Global Write Hexword Threshold (GWHT). The 13-bit value in this field is multiplied by 2^{15} to arrive at the number of hexwords that must be written within the Global DRAM Write Sampling Window to cause the thermal management mechanism to be invoked.
27:22	Write Thermal Management Time (WTMT). This value provides a multiplier between 0 and 63 that specifies how long thermal management remains in effect as a number of Global DRAM Write Sampling Windows. For example, if GDWSW is programmed to 1000_0000b and WTT is set to 01_0000b, then thermal management will be performed for 8192×10^5 host clocks (@ 100 MHz) seconds once invoked ($128 \times 4 \times 10^5$ host clocks * 16).
21:15	Write Thermal Management Monitoring Window (WTMMW). The value in this register is padded with four 0s to specify a window of 0–2047 host clocks with a 16-clock granularity. While the thermal management mechanism is invoked, system memory writes are monitored during this window. If the number of hexwords written during the window reaches the Write Thermal Management Hexword Maximum (bits 14:3), then write requests are blocked for the remainder of the window.
14:3	Write Thermal Management Hexword Maximum (WTMHM). The Write Thermal Management Hexword Maximum defines the maximum number of hexwords between 0–4095 that are permitted to be written to system memory within one Write Thermal Management Monitoring Window.
2:1	Write Thermal Management Mode (WTMMode). 00 = Thermal management via Counters and Hardware Thermal Management_on signal mechanisms disabled. 01 = Hardware Thermal Management_on signal mechanism is enabled. In this mode, as long as the Thermal Management_on signal is asserted, write thermal management is in effect based on the settings in WTMW and WTHM. When the Thermal Management_on signal is deasserted, write thermal management stops and the counters associated with the WTMW and WTHM are reset. When the hardware Thermal Management_on signal mechanism is not enabled, the Thermal Management_on signal has no effects. 10 = Counter mechanism controlled through GDWSW and GWHT is enabled. When the threshold set in GDWSW and GWHT is reached, thermal management start/stop cycles occur based on the settings in WTT, WTMW and WTHM. 11 = Reserved.
0	START Write Thermal Management (SWTM). Software writes to this bit to start and stop write thermal management. 0 = Write thermal management stops and the counters associated with WTMW and WTHM are reset. 1 = Write thermal management begins based on the settings in WTMW and WTHM, and remains in effect until this bit is reset to 0.
0	Reserved.

3.6.24 DRTC—DRAM Read Thermal Management Control Register (Device 1)

Address Offset: 58–5Fh
 Default Value: 0000_0000_0000_0000h
 Access: R/W/L
 Size: 64 bits

Bit	Descriptions
63:41	Reserved.
40:28	Global Read Hexword Threshold (GRHT). The thirteen-bit value held in this field is multiplied by 2^{15} to arrive at the number of hexwords that must be written within the Global DRAM Read Sampling Window to cause the thermal management mechanism to be invoked.
27:22	Read Thermal Management Time (RTMT). This value provides a multiplier between 0 and 63 that specifies how long counter-based read thermal management remains in effect as a number of Global DRAM Read Sampling Windows. For example, if GDRSW is programmed to 1000_0000b and RTT is set to 01_0000b, then read thermal management will be performed for 8192×10^5 host clocks (@ 100 MHz) seconds once invoked ($128 \times 4 \times 10^5$ host clocks * 16).
21:15	Read Thermal Management Monitoring Window (RTMMW). The value in this register is padded with four 0s to specify a window of 0–2047 host clocks with 16-clock granularity. While the thermal management mechanism is invoked, system memory reads are monitored during this window. If the number of hexwords read during the window reaches the Read Thermal Management Hexword Maximum (bits 14:3), then read requests are blocked for the remainder of the window.
14:3	Read Thermal Management Hexword Maximum (RTMHHM). This field defines the maximum number of hexwords between 0–4095 that are permitted to be read from system memory within one Read Thermal Management Monitoring Window.
2:1	Read Thermal Management Mode (RTMMode). 00 = Thermal management via counters and Hardware Thermal Management_on signal mechanisms disabled. 01 = Hardware Thermal Management_on signal mechanism is enabled. In this mode, as long as the Thermal Management_on signal is asserted, read thermal management is in effect based on the settings in RTMW and RTHM. When the Thermal Management_on signal is deasserted, read thermal management stops and the counters associated with the RTMW and RTHM are reset. When the hardware Thermal Management_on signal mechanism is not enabled, the Thermal Management_on signal has no effects. 10 = Counter mechanism controlled through GDRSW and GRHT is enabled. When the threshold set in GDRSW and GRHT is reached, thermal management start/stop cycles occur based on the settings in RTT, RTMW and RTHM. 11 = Reserved.
0	START Read Thermal Management (SRTM). Software writes to this bit to start and stop read thermal management. 0 = Read thermal management stops and the counters associated with RTMW and RTHM are reset. 1 = Read thermal management begins based on the settings in RTMW and RTHM, and remains to be in effect until this bit is reset to 0.



This page is intentionally left blank.

4 System Address Map

A system based on the 845 chipset supports 4 GB of addressable memory space and 64 KB+3 of addressable I/O space. The I/O and memory spaces are divided by system configuration software into regions. The memory ranges are useful either as system memory or as specialized memory, while the I/O regions are used solely to control the operation of devices in the system.

When the MCH receives a write request whose address targets an invalid space, the data is ignored. For reads, the MCH responds by returning all zeros on the requesting interface.

4.1 Memory Address Ranges

The system memory map is broken into two categories:

- **Extended Memory Range (1 MB to 4 GB).** The second is extended memory, existing between 1MB and 4GB. It contains a 32-bit memory space, which is used for mapping PCI, AGP, APIC, SMRAM, and BIOS memory spaces.
- **DOS Compatible Area (below 1 MB).** The final range is a DOS legacy space, which is used for BIOS and legacy devices on the LPC interface.

Figure 3. Addressable Memory Space

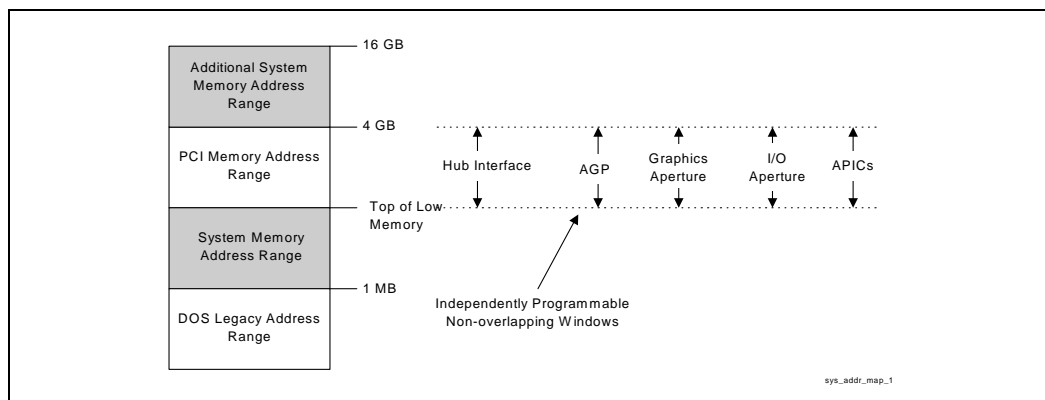

These address ranges are always mapped to system memory, regardless of the system configuration. Memory may be taken out of the system memory segment for use by System Management Mode (SMM) hardware and software. The Top of Low Memory (TOM) register defines the top of system memory.

Note that the address of the highest 16 MB quantity of valid memory in the system is placed into the GBA15 register. For memory populations <3 GB, this value will be the same as the one programmed into the TOM register. For other memory configurations, the two are unlikely to be the same, since the PCI configuration portion of the BIOS software will program the TOM register to the maximum value that is less than the amount of memory in the system and that allows enough room for all populated PCI devices.

Figure 4. DOS Compatible Area Address Map

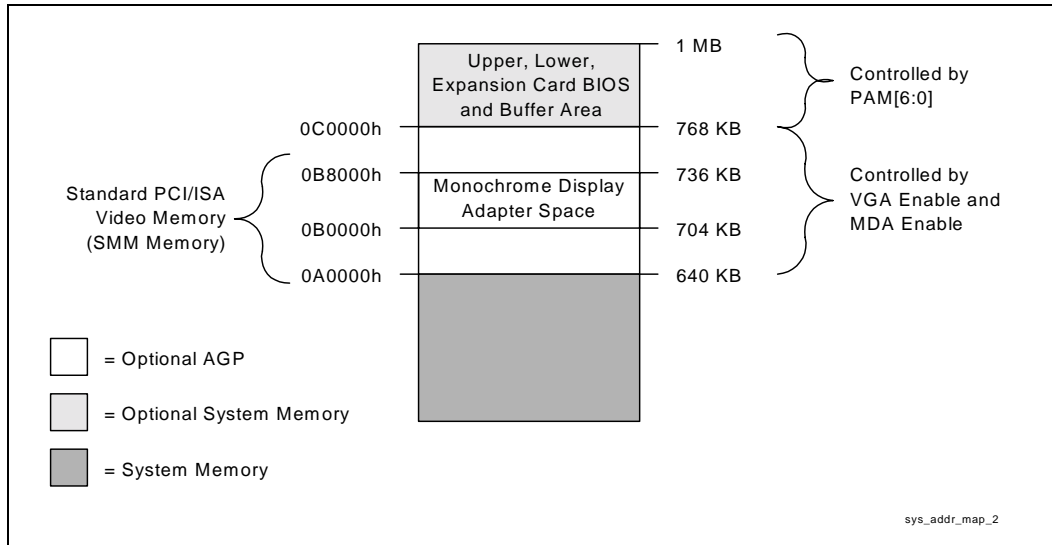
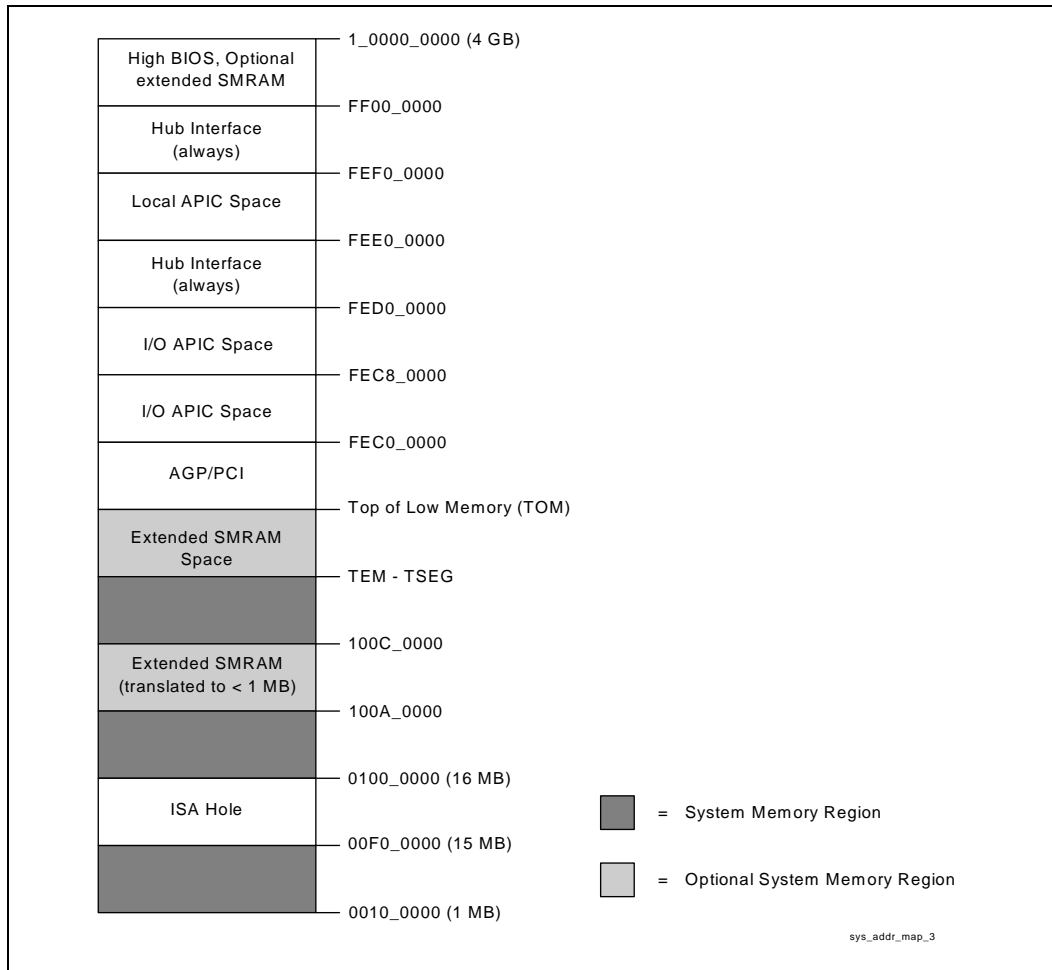

Figure 5. Extended Memory Range Address Map



4.1.1 VGA and MDA Memory Space

Video cards use these legacy address ranges to map a frame buffer or a character-based video buffer. The address ranges in this memory space are:

- VGAA 0_000A_0000 to 0_000A_FFFF
- MDA 0_000B_0000 to 0_000B_7FFF
- VGAB 0_000B_8000 to 0_000B_FFFF

By default, accesses to these ranges are forwarded to the hub interface. However, if the VGA_EN1 bit is set in the BCTRL1 configuration register, transactions within the VGA and MDA spaces are sent to AGP. If the MCHCFG.MDAP configuration bit is set, accesses that fall within the MDA range are sent to the hub interface independent of the setting of the VGA_EN1 bit.

If the MCHCFG.MDAP configuration bit is set, accesses in the MDA range are sent to the hub interface, independent of the setting of the VGA_EN1 bit. Legacy support requires the ability to have a second graphics controller (monochrome) in the system. In an 845 chipset system, accesses in the standard VGA range are forwarded to AGP. Since the monochrome adapter may be on the hub interface or (or ISA) bus, the MCH must decode cycles in the MDA range and forward them to the hub interface. This capability is controlled by a configuration bit (MCHCFG.MDAP). In addition to the memory range B0000h to B7FFFh, the MCH decodes I/O cycles at 3B4h, 3B5h, 3B8h, 3B9h, 3BAh, and 3BFh and forwards them to the hub interface.

An optimization allows the system to reclaim the memory displaced by these regions. If SMM memory space is enabled by SMRAM.G_SMRARE and either the SMRAM.D_OPEN bit is set or the system bus receives an SMM-encoded request for code (not data), then the transaction is steered to system memory rather than the hub interface. Under these conditions, the VGA_EN1 bit and the MDAP bit are ignored.

4.1.2 PAM Memory Spaces

The address ranges in this memory space are:

- PAMC0 0_000C_0000 to 0_000C_3FFF
- PAMC4 0_000C_4000 to 0_000C_7FFF
- PAMC8 0_000C_8000 to 0_000C_BFFF
- PAMCC 0_000C_C000 to 0_000C_FFFF
- PAMD0 0_000D_0000 to 0_000D_3FFF
- PAMD4 0_000D_4000 to 0_000D_7FFF
- PAMD8 0_000D_8000 to 0_000D_BFFF
- PAMDC 0_000D_C000 to 0_000D_FFFF
- PAME0 0_000E_0000 to 0_000E_3FFF
- PAME4 0_000E_4000 to 0_000E_7FFF
- PAME8 0_000E_8000 to 0_000E_BFFF
- PAMEC 0_000E_C000 to 0_000E_FFFF
- PAMF0 0_000F_0000 to 0_000F_FFFF

The 256 KB PAM region is divided into three parts:

- **ISA expansion region;** 128 KB area between 0_000C_0000h–0_000D_FFFFh
- **Extended BIOS region;** 64 KB area between 0_000E_0000h–0_000E_FFFFh
- **System BIOS region;** 64 KB area between 0_000F_0000h–0_000F_FFFFh.

The ISA expansion region is divided into eight 16 KB segments. Each segment can be assigned one of four read/write states: read-only, write-only, read/write, or disabled. Typically, these blocks are mapped through MCH and are subtractively decoded to ISA space.

The extended system BIOS region is divided into four 16 KB segments. Each segment can be assigned independent read and write attributes so it can be mapped either to main system memory or to the hub interface. Typically, this area is used for RAM or ROM.

The system BIOS region is a single 64 KB segment. This segment can be assigned read and write attributes. It is by default (after reset) read/write disabled and cycles are forwarded to the hub interface. By manipulating the read/write attributes, the MCH can “shadow” BIOS into system memory.

4.1.3 ISA Hole Memory Space

BIOS software may optionally open a “window” between 15 MB and 16 MB (0_00F0_0000h to 0_00FF_FFFFh) that relays transactions to the hub interface instead of completing them with a system memory access. This window is opened by programming the FDHC.HEN configuration field.

4.1.4 TSEG SMM Memory Space

The TSEG SMM space (TOM – TSEG to TOM) allows system management software to partition a region of system memory just below the top of low memory (TOM) that is accessible only by system management software. This region may be 128 KB, 256 KB, 512 KB, or 1 MB in size, depending on the ESMRAMC.TSEG_SZ field. SMM memory is globally enabled by SMRAM.G_SMRAME. Requests can access SMM system memory when either SMM space is open (SMRAM.D_OPEN) or the MCH receives an SMM code request on its system bus. To access the TSEG SMM space, TSEG must be enabled by ESMRAMC.T_EN. When all of these conditions are met, then a system bus access to the TSEG space (between TOM–TSEG and TOM) is sent to system memory. If the high SMRAM is not enabled or if the TSEG is not enabled, then all memory requests from all interfaces are forwarded to system memory. If the TSEG SMM space is enabled, and an agent attempts a non-SMM access to TSEG space, then the transaction is specially terminated.

Note: Hub interface and AGP originated accesses are not allowed to SMM space.

4.1.5 IOAPIC Memory Space

The IOAPIC space (0_FEC0_0000h to 0_FEC7_FFFFh) is used to communicate with IOAPIC interrupt controllers that may be populated on the hub interface. Since it is difficult to relocate an interrupt controller using plug-and-play software, fixed address decode regions have been allocated for them. Processor accesses to the IOAPIC0 region are always sent to the hub interface.

4.1.6 System Bus Interrupt APIC Memory Space

The system bus interrupt space (0_FEE0_0000h to 0_FEEF_FFFFh) is the address used to deliver interrupts to the system bus. Any device on AGP may issue a memory write to 0FEEx_xxxxh. The MCH forwards this memory write, along with the data, to the system bus as an Interrupt Message Transaction. The MCH terminates the system bus transaction by providing the response and asserting TRDY#. This memory write cycle does not go to system memory.

4.1.7 High SMM Memory Space

The HIGHSMM space (0_FEDA_0000h to 0_FEDB_FFFFh) allows cacheable access to the compatible SMM space by re-mapping valid SMM accesses between 0_FEDA_0000 and 0_FEDB_FFFF to accesses between 0_000A_0000 and 0_000B_FFFF. The accesses are remapped when SMRAM space is enabled; an appropriate access is detected on the system bus, and when ESMRAMC.H_SMRAME allows access to high SMRAM space. SMM memory accesses from any hub interface or AGP are specially terminated: reads are provided with the value from address 0 while writes are ignored entirely.

4.1.8 AGP Aperture Space (Device 0 BAR)

Processors and AGP devices communicate through a special buffer called the “graphics aperture” (APBASE to APBASE + APSIZE). This aperture acts as a window into main system memory and is defined by the APBASE and APSIZE configuration registers of the MCH. Note that the AGP aperture must be above the top of memory and must not intersect with any other address space.

4.1.9 AGP Memory and Prefetchable Memory

Plug-and-play software configures the AGP memory window to provide enough memory space for the devices behind this PCI-to-PCI bridge. Accesses whose addresses fall within this window are decoded and forwarded to AGP for completion. The address ranges are:

- M1 MBASE1 to MLIMIT1
- PM1 PMBASE1 to PMLIMIT1

Note that these registers must be programmed with values that place the AGP memory space window between the value in the TOM register and 4 GB. In addition, neither region should overlap with any other fixed or relocatable area of memory.

4.1.10 Hub Interface Subtractive Decode

All accesses that fall between the value programmed into the TOM register and 4 GB (i.e., TOM to 4 GB) are subtractively decoded and forwarded to the hub interface if they do not decode to a space that corresponds to another device.

4.2 AGP Memory Address Ranges

The MCH can be programmed to direct memory accesses to the AGP bus interface when addresses are within either of two ranges specified via registers in MCH device 1 configuration space. The first range is controlled via the Memory Base Address (MBASE1) register and Memory Limit Address (MLIMIT1) register. The second range is controlled via the Prefetchable Memory Base Address (PMBASE1) register and Prefetchable Memory Limit Address (PMLIMIT1) register

The MCH positively decodes memory accesses to AGP memory address space as defined by the following equations:

- $\text{Memory_Base_Address} \leq \text{Address} \leq \text{Memory_Limit_Address}$
- $\text{Prefetchable_Memory_Base_Address} \leq \text{Address} \leq \text{Prefetchable_Memory_Limit_Address}$

The plug-and-play configuration software programs the effective size of the range and it depends on the size of memory claimed by the AGP device.

Note: The MCH device 1 memory range registers described above are used to allocate memory address space for any devices sitting on AGP bus that require such a window.

4.2.1 AGP DRAM Graphics Aperture

Memory-mapped, graphics data structures can reside in a Graphics Aperture to system memory. This aperture is an address range defined by the APBASE and APSIZE registers of the MCH device 0. The APBASE register follows the standard base address register template as defined by the *PCI Local Bus Specification, Revision 2.1*. The size of the range claimed by the APBASE is programmed via “back-end” register APSIZE (programmed by the chipset specific BIOS before plug-and-play session is performed). APSIZE allows the BIOS software to pre-configure the aperture size to be 4 MB, 8 MB, 16 MB, 32 MB, 64 MB, 128 MB or 256 MB. By programming APSIZE to a specific size, the corresponding lower bits of APBASE are forced to 0 (behave as hardwired). The default value of APSIZE forces an aperture size of 256 MB. The aperture address range is naturally aligned.

Accesses within the aperture range are forwarded to the system memory subsystem. The MCH translates the originally issued addresses via a translation table maintained in system memory. The aperture range should be programmed as non-cacheable in the processor caches.

Note: Plug-and-play software configuration model does not allow overlap of different address ranges. Therefore the AGP Graphics Aperture and AGP memory address range are independent address ranges that may abut, but cannot overlap one another.

4.3 System Management Mode (SMM) Memory Range

The MCH supports the use of system memory as System Management RAM (SMRAM) enabling the use of System Management Mode. The MCH supports three SMRAM options: Compatible SMRAM (C_SMRAM), High Segment (HSEG), and Top of Memory Segment (TSEG). System Management RAM (SMRAM) space provides a memory area that is available for the SMI handler's and code and data storage. This memory resource is normally hidden from the system OS so that the processor has immediate access to this memory space upon entry to SMM. The MCH provides three SMRAM options:

- Below 1 MB option that supports compatible SMI handlers.
- Above 1 MB option that allows new SMI handlers to execute with write-back cacheable SMRAM.
- Optional larger write-back cacheable T_SEG area from 128 KB to 1 MB in size above 1 MB that is reserved from the highest area in system memory. The above 1 MB solutions require changes to compatible SMRAM handlers' code to properly execute above 1 MB.

Note: Masters from the hub interface and AGP are not allowed to access the SMM space.

4.3.1 SMM Space Definition

Its addressed SMM space and its DRAM SMM space define SMM space. The addressed SMM space is defined as the range of bus addresses used by the processor to access SMM space. System memory SMM space is defined as the range of physical system memory locations containing the SMM code. SMM space can be accessed at one of three transaction address ranges: Compatible, High, and TSEG. The Compatible and TSEG SMM space is not remapped and, therefore, the addressed and DRAM SMM space is the same address range. Since the High SMM space is remapped the addressed and system memory SMM space is a different address range. Note that the High system memory space is the same as the Compatible Transaction Address space. Therefore, the table below describes three unique address ranges:

- Compatible Transaction Address
- High Transaction Address
- TSEG Transaction Address

Table 11. SMM Space Address Ranges

SMM Space Enabled	Transaction Address Space	System Memory Space
Compatible	A0000h to BFFFFh	A0000h to BFFFFh
High	0FEDA0000h to 0FEDBFFFFh	A0000h to BFFFFh
TSEG	(TOM-TSEG_SZ) to TOM	(TOM-TSEG_SZ) to TOM

Note: High SMM: This is different than in some previous chipsets where the High segment was the 384 KB region from A0000h to FFFFFh.

Note: TSEG SMM: Note that this is different than in previous chipsets where the TSEG address space was offset by 256 MB to allow for simpler decoding and the TSEG was remapped to just under the TOM. In the MCH the 256 MB does not offset the TSEG region and it is not remapped.

4.3.2 SMM Space Restrictions

If any of the following conditions are violated, the results of SMM accesses are unpredictable and may cause the system to hang:

- The Compatible SMM space must not be setup as cacheable.
- High or TSEG SMM transaction address space must not overlap address space assigned to system memory, the AGP aperture range, or to any “PCI” devices (including hub interface and AGP devices). This is a BIOS responsibility.
- Both D_OPEN and D_CLOSE must not be set to 1 at the same time.
- When TSEG SMM space is enabled, the TSEG space must not be reported to the OS as available system memory. This is a BIOS responsibility.
- Any address translated through the AGP Aperture GTLB must not target system memory from 000A0000h to 000FFFFFFh.

4.4 I/O Address Space

The MCH does not support the existence of any other I/O devices beside itself on the system bus. The MCH generates either hub interface or AGP bus cycles for all processor I/O accesses. The MCH contains two internal registers in the processor I/O space: Configuration Address (CONF_ADDR) register and Configuration Data (CONF_DATA) register. These locations are used to implement the PCI configuration space access mechanism and as described in Chapter 3.

The processor allows 64 KB+3 bytes to be addressed within the I/O space. The MCH propagates the processor I/O address without any translation on to the destination bus and therefore provides addressability for 64 KB+3 byte locations. Note that the upper 3 locations can be accessed only during I/O address wrap-around when signal A16# address signal is asserted. A16# is asserted on the system bus whenever an I/O access is made to 4 bytes from address 0FFFDh, 0FFFEh, or 0FFFFh. A16# is also asserted when an I/O access is made to 2 bytes from address 0FFFFh.

The I/O accesses (other than ones used for configuration space access) are forwarded normally to the hub interface unless they fall within the AGP I/O address range as defined by the mechanisms explained below. The MCH does not post I/O write cycles to IDE.

The MCH never responds to I/O or configuration cycles initiated on AGP or the hub interface. Hub interface transactions requiring completion are terminated with “master abort” completion packets on the hub interface. Hub interface write transactions not requiring completion are dropped. AGP/PCI I/O reads are never acknowledged by the MCH.

4.5 Intel[®] MCH Decode Rules and Cross-Bridge Address Mapping

The address map described above applies globally to accesses arriving on any of the three interfaces (i.e., processor system bus, hub interface, or AGP).

4.5.1 Hub Interface Decode Rules

The MCH accepts accesses from the hub interface with the following address ranges:

- All memory read and write accesses to main DRAM (except SMM space).
- All memory write accesses from the hub interface to AGP memory range defined by MBASE1, MLIMIT1, PMBASE1, and PMLIMIT1.
- All memory read/write accesses to the Graphics Aperture defined by APBASE and APSIZE.
- Memory writes to VGA range on AGP if enabled.

All memory reads from the hub interface that target >4 GB memory range are terminated with a master abort completion, and all memory writes (>4 GB) from the hub interface are ignored.

4.5.2 AGP Interface Decode Rules

Cycles Initiated Using AGP FRAME# Protocol

The MCH does not support any AGP FRAME# access targeting the hub interface. The MCH claims AGP-initiated memory read and write transactions decoded to the system memory range or the Graphics Aperture range. All other memory read and write requests will be master-aborted by the AGP initiator as a consequence of MCH not responding to a transaction.

Under certain conditions, the MCH restricts access to the DOS Compatibility ranges governed by the PAM registers by distinguishing access type and destination bus. The MCH does NOT accept AGP FRAME# write transactions to the compatibility ranges if the PAM designates system memory as writeable. If accesses to a range are not write-enabled by the PAM, the MCH does not respond and the cycle results in a master-abort. The MCH accepts AGP FRAME# read transactions to the compatibility ranges if the PAM designates system memory as readable. If accesses to a range are not read-enabled by the PAM, the MCH does not respond and the cycle results in a master-abort.

If agent on AGP issues an I/O, PCI Configuration or PCI Special Cycle transaction, the MCH does not respond and cycle results in a master-abort.

Cycles Initiated Using AGP PIPE# or SB Protocol

All cycles must reference system memory; that is, system memory address range (including PAM) or Graphics Aperture range (also physically mapped within system memory but using different address range). AGP accesses to SMM space are not allowed. AGP-initiated cycles that target system memory are not snooped on the host bus, even if they fall outside of the AGP aperture range.

If a cycle is outside of the system memory range, then it terminates as follows:

- Reads remap to memory address 0h, return data from address 0h, and set the IAAF error bit in ERRSTS register in device 0
- Writes are terminated internally without affecting any chip signals or system memory

AGP Accesses to MCH that Cross Device Boundaries

For AGP FRAME# accesses, when an AGP master gets disconnected, it resumes at the new address which allows the cycle to be routed to or claimed by the new target. Therefore, the target on potential device boundaries should disconnect accesses. The MCH disconnects AGP FRAME# transactions on 4 KB boundaries.

AGP PIPE# and SBA accesses are limited to 256 bytes and must hit system memory. Read accesses crossing a device boundary will return invalid data when the access crosses out of system memory. Write accesses crossing out of system memory will be discarded. The IAAF Error bit will be set.

5 *Functional Description*

This chapter describes the system bus that connects the MCH to the processor, the system memory interface, the AGP interface, the MCH power and thermal management, the MCH clocking, and the MCH system reset and power sequencing.

5.1 System Bus

The MCH supports the Pentium 4 processor subset of the Enhanced Mode Scaleable Bus. Source synchronous transfers are used for the address and data signals. The address signals are double pumped and a new address can be generated every other bus clock. At 100 MHz bus frequency, the address signals run at 200 MT/s for a maximum address queue rate of 50 M addresses/sec. The data is quad pumped and an entire 64-byte cache line can be transferred in two bus clocks. At 100 MHz bus frequency, the data signals run at 400 MT/s for a maximum bandwidth of 3.2 GB/s. The MCH supports a 12 deep IOQ.

The MCH supports two outstanding deferred transactions on the system bus. The two transactions must target different I/O interfaces as only one deferred transaction can be outstanding to any single I/O interface at a time.

5.1.1 Dynamic Bus Inversion

The MCH supports Dynamic Bus Inversion (DBI) when driving and receiving data from the system bus. DBI limits the number of data signals that are driven to a low voltage on each quad pumped data phase. This decreases the power consumption of the MCH. DBI[3:0]# indicates if the corresponding 16 bits of data are inverted on the bus for each quad pumped data phase:

DBI[3:0]#	Data Bits
DBI0#	HD[15:0]#
DBI1#	HD[31:16]#
DBI2#	HD[47:32]#
DBI3#	HD[63:48]#

When the processor or the MCH drives data, each 16-bit segment is analyzed. If more than 8 of the 16 signals would normally be driven low on the bus, the corresponding DBI# signal will be asserted and the data will be inverted prior to being driven on the bus. When the processor or the MCH receives data, it monitors DBI[3:0]# to determine if the corresponding data segment should be inverted.

5.1.2 System Bus Interrupt Delivery

The Pentium 4 processor supports the system bus interrupt delivery; the APIC serial bus interrupt delivery mechanism is not supported. Interrupt-related messages are encoded on the system bus as “Interrupt Message Transactions”. In an 845 chipset platform, system bus interrupts can originate from the processor on the system bus, or from a downstream device on the hub interface or AGP. In the later case the MCH drives the “Interrupt Message Transaction” onto the system bus.

In an 845 chipset platform, the ICH2 contains IOxAPICs, and its interrupts are generated as upstream hub interface memory writes. Furthermore, PCI 2.2 defines MSIs (Message Signaled Interrupts) that are also in the form of memory writes. A PCI 2.2 device can generate an interrupt as an MSI cycle on its PCI bus, instead of asserting a hardware signal to the IOxAPIC. The MSI can be directed to the IOxAPIC, which in turn generates an interrupt as an upstream hub interface memory write. Alternatively, the MSI can be directed directly to the system bus. The target of a MSI is dependent on the address of the interrupt memory write. The MCH forwards inbound hub interface and AGP (PCI semantic only) memory writes to address 0FEE_x_xxxxh, to the system bus as “Interrupt Message Transactions”.

5.1.3 Upstream Interrupt Messages

The MCH accepts message-based interrupts from AGP (PCI semantics only) or its hub interface and forwards them to the system bus as Interrupt Message Transactions. The interrupt messages presented to the MCH are in the form of memory writes to address 0FEE_x_xxxxh. At the hub interface or AGP interface, the memory write interrupt message is treated like any other memory write; it is either posted to the inbound data buffer (if space is available) or retried (if data buffer space is not immediately available). Once posted, the memory write from AGP or the hub interface to address 0FEE_x_xxxxh is decoded as a cycle that needs to be propagated by the MCH to the system bus as an Interrupt Message Transaction.

5.2 System Memory Interface

The 845 chipset can be configured to support PC133 SDRAM.

5.2.1 Single Data Rate (SDR) SDRAM Interface Overview

The MCH integrates a system memory SDRAM controller with a 64-bit wide interface and twelve system memory clock signals (each at 133 MHz). The MCH's system memory buffers support LVTTTL (SDRAM) signaling at 133 MHz.

The MCH includes support for:

- Up to 3 GB of 133 MHz SDR SDRAM
- PC133 unbuffered 168 pin SDR SDRAM DIMMs
- Maximum of 3 DIMMs, single-sided and/or double-sided
- Configurable optional ECC

The two bank-select lines SBS[1:0] and the thirteen address lines (SMA[12:0]) allow the MCH to support 64-bit wide DIMMs using 64 Mb, 128 Mb, 256 Mb, and 512 Mb SDRAM technologies. While address lines SMA[9:0] determine the starting address for a burst, burst lengths are fixed at four. Twelve chip selects SCS# lines allow a maximum of three rows of single-sided SDRAM DIMMs and six rows of double-sided SDRAM DIMMs.

The MCH's system memory controller targets CAS latencies of 2 and 3 clocks for SDRAM. The MCH provides refresh functionality with a programmable rate (normal SDRAM rate is 1 refresh/15.6 us).

5.2.2 Memory Organization and Configuration

In the following discussion the term *row* refers to a set of memory devices that are simultaneously selected by a SCS# signal. The MCH supports a maximum of 6 rows of memory. For the purposes of this discussion, a "side" of a DIMM is equivalent to a "row" of SDRAM devices.

Table 12. Supported DIMM Configurations

Density	64 Mbit		128 Mbit		256 Mbit		512 Mbit	
Device Width	X8	X16	X8	X16	X8	X16	X8	X16
Single \ Double	SS/DS	SS/DS	SS/DS	SS/DS	SS/DS	SS/DS	SS/DS	SS/DS
168 pin SDR DIMMs	64 MB / 128 MB	32 MB / 64 MB	128 MB / 256 MB	64 MB / 128 MB	256 MB / 512 MB	128 MB / 256 MB	512 MB / 1024 MB	256 MB / 512 MB

5.2.2.1 Configuration Mechanism For DIMMs

Detection of the type of SDRAM installed on the DIMM is supported via a Serial Presence Detect mechanism as defined in the JEDEC 168-pin DIMM specification. This uses the SCL, SDA and SA[2:0] pins on the DIMMs to detect the type and size of the installed DIMMs. No special programmable modes are provided on the MCH for detecting the size and type of memory installed. Type and size detection must be done via the serial presence detection pins.

Memory Detection and Initialization

Before any cycles to the memory interface can be supported, the MCH SDRAM registers must be initialized. The MCH must be configured for operation with the installed memory types. Detection of memory type and size is accomplished via the System Management Bus (SMBus) interface on the ICH2. This two-wire bus is used to extract the SDRAM type and size information from the Serial Presence Detect port on the SDRAM DIMMs. SDRAM DIMMs contain a 5-pin Serial Presence Detect interface, including SCL (serial clock), SDA (serial data), and SA[2:0]. Devices on the SMBus bus have a seven-bit address. For the SDRAM DIMMs, the upper four bits are fixed at 1010. The lower three bits are strapped on the SA[2:0] pins. SCL and SDA are connected directly to the system management bus on the ICH2. Thus, data is read from the Serial Presence Detect port on the DIMMs via a series of I/O cycles to the ICH2. BIOS needs to determine the size and type of memory used for each of the rows of memory to properly configure the MCH memory interface.

SMBus Configuration and Access of the Serial Presence Detect Ports

For more details on SMBus Configuration and Serial Present Detect Ports, see the *Intel® 82801BA I/O Controller Hub 2 (ICH2) and 82801BAM I/O Controller Hub 2 Mobile (ICH2-M) Datasheet*.

Memory Register Programming

This section provides an overview of how the required information for programming the SDRAM registers is obtained from the Serial Presence Detect ports on the DIMMs. The Serial Presence Detect ports are used to determine refresh rate, MA and MD buffer strength, row type (on a row by row basis), SDRAM Timings, row sizes and row page sizes. Table 13 lists a subset of the data available through the on-board Serial Presence Detect ROM on each DIMM.

Table 13. Data Bytes on DIMM Used for Programming DRAM Registers

Byte	Function
2	Memory type (SDR SDRAM or DDR SDRAM)
3	Number of row addresses, not counting bank addresses
4	Number of column addresses
5	Number of banks of SDRAM (single- or double-sided DIMM)
11	ECC, no ECC
12	Refresh rate
17	Number banks on each device

Table 13 is only a subset of the defined SPD bytes on the DIMMs. These bytes collectively provide enough data for programming the MCH SDRAM registers.



5.2.3 Memory Address Translation and Decoding

The 845 MCH contains address decoders that translate the address received on the system bus or the hub interface. Decoding and translation of these addresses vary with the four SDRAM types. Also, the number of pages, page sizes, and densities supported vary with the type. In general, the MCH supports 64 Mb, 128 Mb, 256 Mb, and 512 Mb SDRAM devices. The multiplexed row/column address to the SDRAM memory array is provided by the SBS[1:0] and SMA[12:0] signals. These addresses are derived from the system address bus as defined by Table 14 for SDRAM devices.

Table 14. Address Translation and Decoding

Tech.	Configuration	Row size Page size	Row / Column / Bank	Row Col	Addr	BA1	BA0	A12	A11	A10	A9	A8	A7	A6	A5	A4	A3	A2	A1	A0
64 Mb	1Meg x 16 x 4 bks	32 MB	12x8x2	Row	24	11	12		24	13	14	15	16	23	22	21	20	19	18	17
		2 KB		Col					AP			10	9	8	7	6	5	4	3	
64 Mb	2Meg x 8 x 4 bks	64 MB	12x9x2	Row	25	13	12		24	25	14	15	16	23	22	21	20	19	18	17
		4 KB		Col					AP		11	10	9	8	7	6	5	4	3	
128 Mb	2Meg x 16 x 4bks	64 MB	12x9x2	Row	25	13	12		24	25	14	15	16	23	22	21	20	19	18	17
		4 KB		Col					AP		11	10	9	8	7	6	5	4	3	
128 Mb	4Meg x 8 x 4bks	128 MB	12x10x2	Row	26	14	13		26	25	24	15	16	23	22	21	20	19	18	17
		8 KB		Col					AP	12	11	10	9	8	7	6	5	4	3	
256 Mb	4Meg x 16 x 4 bks	128 MB	13x9x2	Row	26	13	12	26	24	25	14	15	16	23	22	21	20	19	18	17
		4 KB		Col					AP		11	10	9	8	7	6	5	4	3	
256 Mb	8Meg x 8 x 4 bks	256 MB	13x10x2	Row	27	14	13	27	26	25	24	15	16	23	22	21	20	19	18	17
		8 KB		Col					AP	12	11	10	9	8	7	6	5	4	3	
512 Mb	8Meg x 16 x 4bks	256 MB	13x10x2	Row	27	14	13	27	26	25	24	15	16	23	22	21	20	19	18	17
		8 KB		Col					AP	12	11	10	9	8	7	6	5	4	3	
512 Mb	16Meg x 8 x 4bks	512 MB	13x11x2	Row	28	14	15	27	26	25	24	28	16	23	22	21	20	19	18	17
		16 KB		Col					13	AP	12	11	10	9	8	7	6	5	4	3

5.2.4 DRAM Performance Description

The overall memory performance is controlled by the DRAM Timing (DRT) Register, pipelining depth used in the MCH, memory speed grade, and the type of SDRAM used in the system. In addition, the exact performance in a system is also dependent on the total memory supported, external buffering, and memory array layout. The most important contribution to overall performance by the system memory controller is to minimize the latency required to initiate and complete requests to memory and to support the highest possible bandwidth (full streaming, quick turn-arounds). One measure of performance is the total flight time to complete a cache line request. A complete discussion of performance involves the entire chipset, not just the system memory controller.

5.2.4.1 Data Integrity (ECC)

The MCH supports single-bit Error Correcting Code (or Error Checking and Correcting) and multiple-bit EC (Error Checking) on the system memory interface. The MCH generates an 8-bit code word for each 64-bit QWord of memory. The MCH performs two QWord writes at a time; thus, two 8-bit codes are sent with each write. Since the code word covers a full QWord, writes of less than a QWord require a read-merge-write operation. Consider a DWord write to memory. In this case, when in ECC mode, the MCH reads the QWord where the addressed DWord will be written, merges in the new DWord, generates a code covering the new QWord, and, finally, writes the entire QWord and code back to memory. Any correctable (single-bit) errors detected during the initial QWord read are corrected before merging the new DWord.

The MCH also supports EC (Error Checking) data integrity mode. In this mode, the MCH generates and stores a code for each QWord of memory. It then checks the code for reads from memory but does not correct any errors that are found. Thus, the read performance hit associated with ECC is not incurred.

5.3 AGP Interface Overview

The MCH supports 1.5 V AGP 1x/2x/4x devices. The AGP signal buffers are 1.5 V drive/receive (buffers are not 3.3 volt tolerant). The MCH supports 2x/4x source synchronous clocking transfers for read and write data, and sideband addressing. The MCH also support 2x and 4x clocking for Fast Writes initiated from the MCH (on behalf of the processor).

AGP PIPE# or SBA[7:0] transactions to system memory do not get snooped and are, therefore, not coherent with the processor caches. AGP FRAME# transactions to system memory are snooped. AGP PIPE# and SBA[7:0] accesses to and from the hub interface are not supported. AGP FRAME# access from an AGP master to the hub interface are also not supported. Only the AGP FRAME memory writes from the hub interface are supported.

5.3.1 AGP Target Operations

As an initiator, the MCH does not initiate cycles using AGP enhanced protocols. The MCH supports AGP cycles targeting the interface to system memory only. The MCH supports interleaved AGP PIPE# and AGP FRAME#, or AGP SBA[7:0] and AGP FRAME# transactions.

Table 15. AGP Commands Supported by the Intel® MCH When Acting as an AGP Target

AGP Command	C/BE[3:0]# Encoding	MCH Host Bridge	
		Cycle Destination	Response as PCIx Target
Read	0000	System memory	Low-priority read
	0000	Hub interface	Complete with random data
Hi-Priority Read	0001	System memory	High-priority read
	0000	The Hub interface	Complete with random data
Reserved	0010	N/A	No response
Reserved	0011	N/A	No response
Write	0100	System memory	Low-priority write
	0100	Hub interface	Cycle goes to DRAM with byte enables inactive
Hi-Priority Write	0101	System memory	High-priority write
	0101	Hub interface	Cycle goes to DRAM with byte enables inactive; does not go to the hub interface
Reserved	0110	N/A	No response
Reserved	0111	N/A	No response
Long Read	1000	System memory	Low-priority read
		Hub interface	Complete locally with random data; does not go to the hub interface
Hi-Priority Long Read	1001	System memory	High-priority read
		Hub interface	Complete with random data
Flush	1010	MCH	Complete with QW of random data
Reserved	1011	N/A	No response
Fence	1100	MCH	No response; Flag inserted in MCH request queue
Reserved	1101	N/A	No response
Reserved	1110	N/A	No response
Reserved	1111	N/A	No response

NOTES:

1. N/A refers to a function that is not applicable

As a target of an AGP cycle, the MCH supports all the transactions targeting system memory (summarized in Table 15). The MCH supports both normal and high-priority read and write requests. The MCH does not support AGP cycles to the hub interface. PIPE# and SBA cycles do not require coherency management and all AGP initiator accesses to system memory, using AGP PIPE# or SBA protocol, are treated as non-snoopable cycles. These accesses are directed to the AGP aperture in system memory that is programmed as either uncacheable (UC) memory or write combining (WC) in the processor's MTRRs.

5.3.2 AGP Transaction Ordering

The MCH observes transaction ordering rules as defined by the *AGP Interface Specification, Revision 2.0*.

5.3.3 AGP Signal Levels

The 4x data transfers use 1.5 V signaling levels as described by the *AGP Interface Specification, Revision 2.0*. The MCH supports 1x/2x data transfers using 1.5 V signaling levels.

5.3.4 4x AGP Protocol

In addition to the 1x and 2x AGP protocol, the MCH supports 4x AGP read and write data transfers and 4x sideband address generation. The 4x operation is compliant with the *AGP Interface Specification, Revision 2.0*.

The MCH indicates that it supports 4x data transfers via bit 2 of the AGPSTAT.RATE field. When bit 2 of the AGPCMD.DRATE field is set to 1 during system initialization, the MCH performs AGP read/write data transactions using 4x protocol. This bit is not dynamic. Once this bit is set during initialization, the data transfer rate must not be changed.

The 4x data rate transfer provides 1.06 GB/s transfer rates. The control signal protocol for the 4x data transfer protocol is identical to 1x/2x protocol. In 4x mode 16 bytes of data are transferred on every 66 MHz clock edge. The minimum throttleable block size remains four 66 MHz clocks (64 bytes of data are transferred per block). Three additional signal pins are required to implement the 4x data transfer protocol. These signal pins are complimentary data transfer strobes for the AD bus (2) and the SBA bus (1).

5.3.5 Fast Writes

The MCH supports 2x and 4x Fast Writes from the MCH to the graphics controller on AGP. Fast Write operation is compliant with Fast Writes as currently described in the *AGP Interface Specification, Revision 2.0*. To use the Fast Write protocol, both AGPCTRL.FWCE and AGPCMD.FWPE must be set to 1.

AGPCTRL.FWCE is set to 0 by default. When this bit is set to 1, the MCH indicates that it supports Fast Writes through AGPSTAT.FW. When both AGPCMD.FWEN and AGPCTRL.FWCE are set to 1, the MCH uses Fast Write protocol to transfer memory write data to the AGP master.

Memory writes originating from the processor or from the hub interface use the Fast Write protocol when it is both capability enabled and enabled. The data rate used to perform the Fast Writes is dependent on the bits set in the AGPCMD.DRATE field (bits [2:0]). If bit 2 of the AGPCMD.DRATE field is 1, the data transfers occur using 4x strobing. If bit 1 of AGPCMD.DRATE field is 1, the data transfers occur using 2x strobing. If bit 0 of AGPCMD.DRATE field is 1, Fast Writes are disabled and data transfers occur using standard PCI protocol. Note that only one of the three DRATE bits can be set by initialization software (Table 16).

Table 16. Data Rate Control Bits

AGPCNTL .FWCE	AGPCMD. FWPE	AGPCMD. DRATE [bit 2]	AGPCMD. DRATE [bit 1]	AGPCMD. DRATE [bit 0]	MCH =>AGP Master Write Protocol
0	0	X	X	X	1x
1	1	0	0	1	1x
1	1	0	1	0	2x strobing
1	1	1	0	0	4x strobing

5.3.6 AGP FRAME# Transactions on AGP

The MCH accepts and generates AGP FRAME# transactions on the AGP bus. The MCH guarantees that AGP FRAME# accesses to system memory are kept coherent with the processor caches by generating snoops to the host bus. LOCK#, SERR#, and PERR# signals are not supported.

MCH Initiator and Target Operations

Table 17 summarizes MCH target operation for AGP FRAME# initiators. The cycles can be either destined to system memory or the hub interface.

Table 17. PCI Commands Supported by the Intel® MCH (When Acting as a FRAME# Target)

PCI Command	C/BE[3:0]#	Intel® MCH	
	Encoding	Cycle Destination	Response as a FRAME# Target
Interrupt Acknowledge	0000	N/A	No response
Special cycle	0001	N/A	No response
I/O Read	0010	N/A	No response
I/O Write	0011	N/A	No response
Reserved	0100	N/A	No response
Reserved	0101	N/A	No response
Memory Read	0110	System memory	Read
	0110	Hub interface	No response
Memory Write	0111	System memory	Posts data
	0111	Hub interface	No response
Reserved	1000	N/A	No response
Reserved	1001	N/A	No response
Configuration Read	1010	N/A	No response
Configuration Write	1011	N/A	No response
Memory Read Multiple	1100	System memory	Read
	1100	Hub interface	No response

PCI Command	C/BE[3:0]#	Intel® MCH	
	Encoding	Cycle Destination	Response as a FRAME# Target
Dual Address Cycle	1101	N/A	No response
Memory Read Line	1110	System Memory	Read
	1110	Hub interface	No response
Memory Write and Invalidate	1111	System memory	Posts data
	1111	Hub interface	Posts Data

NOTES:

1. N/A refers to a function that is not applicable

As a **target** of an AGP FRAME# cycle, the MCH only supports the following transactions:

- *Memory Read, Memory Read Line, and Memory Read Multiple.* These commands are supported identically by the MCH. The MCH does not support reads of the hub interface bus from AGP.
- *Memory Write and Memory Write and Invalidate.* These commands are aliased and processed identically.
- *Other Commands.* Other commands (e.g., I/O R/W and Configuration R/W) are not supported by the MCH as a target and result in master abort.
- *Exclusive Access.* The MCH does not support PCI locked cycles as a target.
- *Fast Back-to-Back Transactions.* The MCH, as a target, supports fast back-to-back cycles from an AGP FRAME# initiator.

As an **initiator** of AGP FRAME# cycle, the MCH only supports the following transactions:

- *Memory Read and Memory Read Line.* MCH supports reads from host to AGP. MCH does not support reads from the hub interface to AGP.
- *Memory Read Multiple.* This command is not supported by the MCH as an AGP FRAME# initiator.
- *Memory Write.* The MCH initiates AGP FRAME# cycles on behalf of the host or the hub interface. As an initiator, the MCH does not issue Memory Write and Invalidate cycles. The MCH does not support write merging or write collapsing. The MCH allows non-snoopable write transactions from the hub interface to the AGP bus.
- *I/O Read and Write.* I/O read and write cycles from the host are sent to the AGP bus. The I/O base and limit address range for the AGP bus are programmed in the configuration registers. All other accesses that do not correspond to this programmed address range are forwarded to the hub interface.
- *Exclusive Access.* The MCH does not issue a locked cycle on the AGP bus on behalf of either the host or the hub interface. The hub interface and host locked transactions to AGP are initiated as unlocked transactions by the MCH on the AGP bus.
- *Configuration Read and Write.* Host configuration cycles to AGP are forwarded as Type 1 configuration cycles.
- *Fast Back-to-Back Transactions.* The MCH, as an initiator, does not perform fast back-to-back cycles.

MCH Retry/Disconnect Conditions

The MCH generates retry/disconnect according to the *AGP Interface Specification, Revision 2.0* rules when being accessed as a target from the AGP FRAME# device.

Delayed Transaction

When an AGP FRAME#-to-system memory read cycle is retried by the MCH, it is processed internally as a delayed transaction. The MCH supports the delayed transaction mechanism on the AGP target interface for the transactions issued using AGP FRAME# protocol. This mechanism is compatible with the *PCI Local Bus Specification, Revision 2.1*. The process of latching all information required to complete the transaction, terminating with Retry, and completing the request without holding the master in wait-states is called a *delayed transaction*.

The MCH latches the address and command when establishing a delayed transaction. The MCH generates a delayed transaction on the AGP only for AGP FRAME# to system memory read accesses. The MCH does not allow more than one delayed transaction access from AGP at any time.

5.4 Power and Thermal Management

An 845 chipset platform is compliant with the following specifications:

- APM, Revision 1.2
- ACPI, Revision 1.0b
- PCI Power Management, Revision 1.0
- PC '99, Revision 1.0
- PC '99A
- PC '01, Revision 1.0

5.4.1 Processor Power State Control

- **C0 (Full On):** This is the only state that runs software. All clocks are running, STPCLK# is deasserted, and the processor core is active. The processor can service snoops and maintain cache coherency in this state.
- **Stop-Grant State:** This function can be enabled or disabled via a configuration bit. When this function is enabled, STPCLK# is asserted to place the processor into the C2 state with a programmable duty cycle. This is an ACPI defined function but BIOS or APM (via BIOS) can use this facility.

5.4.2 Sleep State Control

- **S0 (Awake):** In this state all power planes are active. All of the ACPI software “C” states are embedded in this state.
- **S1:** The recommended implementation of S1 state is the same as C2 state (Stop Grant), which is entered by the assertion of the STPCLK# signal from the ICH2 to the processor. A further power saving can be achieved by asserting processor SLP# from the ICH2. This puts the processor into Sleep State.
- **S2:** ACPI S2 state is not supported in the 845 chipset desktop platform.
- **S3 (Suspend To RAM (STR)):** The next level of power reduction occurs when the clock synthesizers and main power planes (ICH2, MCH, and the processor) are shut down but the system memory plane and the ICH2 resume well remain active. This is the Suspend-to-RAM (STR) state. All clocks from synthesizers are shut down during the S3 state.
- **S4 and S5 (Suspend To Disk (STD), Soft Off):** The next level of power reduction occurs when the memory power and MCH are shut down in addition to the clock synthesizers, ICH2, and the processor power planes. The ICH2 resume well is still powered.
- **G3 (Mechanical Off):** In this state only the RTC well is powered. The system can only reactivate when the power switch is returned to the “On” position.

5.5 Intel[®] MCH Clocking

The 845 chipset is supported by the CK_408 compliant clock synthesizer. For details on clocking, refer to the *Intel[®] Pentium 4 Processor in a 478 Pin Package and Intel[®] 845 Chipset Platform Design Guide*.

5.6 Intel[®] MCH System Reset and Power Sequencing

For details on MCH system reset and power sequencing, refer to the *Intel[®] Pentium 4 Processor in a 478 Pin Package and Intel[®] 845 Chipset Platform Design Guide*.

6 Electrical Characteristics

This chapter contains the absolute maximum operating ratings, power characteristics, and DC characteristics for the 82845 MCH.

6.1 Absolute Maximum Ratings

Table 18 lists the MCH's maximum environmental stress ratings. Functional operation at the absolute maximum and minimum is neither implied nor guaranteed. Functional operating parameters are listed in the DC tables.

Warning: Stressing the device beyond the “Absolute Maximum Ratings” may cause permanent damage. These are stress ratings only. Operating beyond the “operating conditions” is not recommended and extended exposure beyond “operating conditions” may affect reliability.

Table 18. Absolute Maximum Ratings

Symbol	Parameter	Min	Max	Unit	Notes
Tstorage	Storage Temperature	-55	150	°C	
VCC1_5	1.5 V Supply Voltage with respect to VSS	-0.72	2.3	V	
VCC1_8	1.8 V Supply Voltage with respect to VSS	-0.88	2.69	V	
VCCSM	3.3 V Supply Voltage with respect to VSS	-2.83	6.3	V	
VTT	AGTL+ buffer DC input voltage with respect to VSS	-0.55	2.3	V	

6.2 Power Characteristics

Table 19. Power Characteristics

Symbol	Parameter	Min	Typ	Max	Unit	Notes
I _{VTT}	MCH VTT supply current			2.4	A	
I _{VCC1_5_CORE}	1.5 V core supply current			1.5	A	1
I _{VCC1_5_AGP}	1.5 V AGP supply current			0.37	A	1
I _{VCC1_8}	1.8 V hub interface supply current			0.20	A	
I _{VCCSM}	3.3 V system memory supply current			2.0	A	
I _{SUS_3.3}	3.3 V standby supply current			25	mA	
	HVREF, AGPREF, HI_REF, SDREF supply current			10	mA	

NOTES:

1. These current levels can happen simultaneously, and can be summed into one supply.

6.3 Signal Groups

The signal description includes the type of buffer used for the particular signal:

- AGTL+** Open Drain AGTL+ interface signal. Refer to the AGTL+ I/O Specification for complete details. The MCH integrates most AGTL+ termination resistors.
- AGP** AGP interface signals. These signals are compatible with AGP 2.0 1.5 V Signaling Environment DC and AC Specifications. The buffers are not 3.3 V tolerant.
- HI CMOS** Hub Interface 1.8 V CMOS buffers.
- SM CMOS** System memory 3.3 V CMOS buffers.

Table 20. Signal Groups

Signal Group	Signal Type	Signals
(a)	AGTL+ I/O	ADS#, BNR#, BR0#, DBSY#, DBI[3:0]#, DRDY#, HA[31:3]#, HADSTB[1:0] #, HD[63:0]#, HDSTBP[3:0]#, HDSTBN[3:0]#, HIT#, HITM#, HREQ[4:0]#
(b)	AGTL+ Output	BPRI#, CPURST#, DEFER#, HTRDY#, RS[2:0]#
(c)	AGTL+ Input	HLOCK#
(d)	Host Reference Voltages	HVREF, HSWING[1:0]
(e)	AGP I/O	AD_STB0, AD_STB0#, AD_STB1, AD_STB1#, G_FRAME#, G_IRDY#, G_TRDY#, G_STOP#, G_DEVSEL#, G_AD[31:0], G_C/BE[3:0]#, G_PAR
(f)	AGP Input	PIPE#, SBA[7:0], RBF#, WBF#, SB_STB, SB_STB#, G_REQ#
(g)	AGP Output	ST[2:0], G_GNT#
(h)	AGP Reference Voltage	AGPREF
(i)	Hub Interface's CMOS I/O	HI_[10:0], HI_STB, HI_STB#
(j)	Hub Interface Reference Voltage	HI_REF
(k)	SDRAM CMOS I/O	SDQ[63:0], SCB[7:0]
(l)	SDRAM CMOS Output	SCS[11:0]#, SMA[12:0], SBS[1:0], SRAS#, SCAS#, SWE#, SCKE[5:0], SCK[11:0], RDCLKO
(m)	SDRAM CMOS Input	RDCLKI
(n)	SDRAM Reference Voltage	SDREF
(o)	CMOS Input	TESTIN#
(p)	CMOS Input	RSTIN# (3.3V)
(r)	AGTL+ Termination Voltage	VTT



Signal Group	Signal Type	Signals
(s)	1.5 V Core and AGP Voltage	VCC1_5
(t)	1.8 V Hub Interface Voltage	VCC1_8
(u)	3.3 V PC133 SDRAM I/O Voltage	VCCSM
(v)	CMOS Clock Input	66IN
(w)	CMOS Clock Input	BCLK, BCLK#

6.4 DC Characteristics

Table 21. DC Characteristics

Symbol	Signal Group	Parameter	Min	Typ	Max	Unit	Notes
I/O Buffer Supply Voltage							
VCCSM	(u)	PC133 SDRAM I/O Voltage	3.135	3.3	3.465	V	
VCC1_8	(t)	1.8V I/O Supply Voltage	1.71	1.8	1.89	V	
VCC1_5	(s)	Core and AGP Voltage	1.425	1.5	1.575	V	
VTT	(r)	Host AGTL+ Termination Voltage	N/A	N/A	1.75	V	
Reference Voltages							
HVREF	(d)	Host Address and Data Reference Voltage	$(2/3 \times VTT) - 2\%$	$2/3 \times VTT$	$(2/3 \times VTT) + 2\%$	V	
HSWING	(d)	Host Compensation Reference Voltage	$(1/3 \times VTT) - 2\%$	$1/3 \times VTT$	$(1/3 \times VTT) + 2\%$	V	
HI_REF	(j)	Hub Interface Reference Voltage	$0.48 \times VCC1_8$	$1/2 \times VCC1_8$	$0.52 \times VCC1_8$	V	
SDREF	(n)	SDRAM Reference Voltage	$0.49 \times VCCSM$	$1/2 \times VCCSM$	$0.51 \times VCCSM$	V	
AGPREF	(h)	AGP Reference Voltage	$0.48 \times VCC1_5$	$1/2 \times VCC1_5$	$0.52 \times VCC1_5$	V	
System Bus Interface							
V _{IL}	(a,c)	Host AGTL+ Input Low Voltage			$(2/3 \times VTT) - 0.1$	V	
V _{IH}	(a,c)	Host AGTL+ Input High Voltage	$(2/3 \times VTT) + 0.1$			V	
V _{OL}	(a,b)	Host AGTL+ Output Low Voltage			$(1/3 \times VTT) + 0.1$	V	
V _{OH}	(a,b)	Host AGTL+ Output High Voltage	$VTT - 0.1$			V	
I _{OL}	(a,b)	Host AGTL+ Output Low Current			$VTT_{max} / 0.75R_{tt}$	mA	R _{tt} _{min} = 45 Ω R _{tt} _{typ} = 50 Ω R _{tt} _{max} = 55 Ω
I _{LEAK}	(a,c)	Host AGTL+ Input Leakage Current			±15	μA	V _{OL} < V _{pad} < VTT
C _{PAD}	(a,c)	Host AGTL+ Input Capacitance		1.0		pF	
3.3 V Interface							
V _{IL}	(k,m,p)	Input Low Voltage			SDREF - 2.0	V	
V _{IH}	(k,m,p)	Input High Voltage	SDREF + 2.0			V	
V _{OL}	(k,l)	Output Low Voltage			0.4	V	
V _{OH}	(k,l)	Output High Voltage	2.4			V	
I _{OL}	(k,l)	Output Low Current			4	mA	@V _{OL,S} max
I _{OH}	(k,l)	Output High Current	-4			mA	@V _{OH,S} max
I _{LEAK}	(k,m,p)	Input Leakage Current			±100	μA	0 < V _{in} < VCC3_3

Symbol	Signal Group	Parameter	Min	Typ	Max	Unit	Notes
C _{I/O}	(k,m,p)	Input Capacitance	4.65		5.37	pF	
1.5 V Interface							
V _{IL}	(e,f)	Input Low Voltage			0.4 x VCC1_5	V	
V _{IH}	(e,f)	Input High Voltage	0.6 x VCC1_5			V	
V _{OL}	(e,g)	Output Low Voltage			0.15 x VCC1_5	V	
V _{OH}	(e,g)	Output High Voltage	0.85 x VCC1_5			V	
I _{OL}	(e,g)	Output Low Current			1	mA	@V _{OL,A} max
I _{OH}	(e,g)	Output High Current	-0.2			mA	@V _{OH,A} max
I _{LEAK}	(e,f)	Input Leakage Current			±15	µA	0<V _{in} <VCC1_5
C _{IN}	(e,f)	Input Capacitance	1.32		1.92	pF	
1.8 V Interface							
V _{IL}	(i,o)	Input Low Voltage			HI_REF – 0.15	V	
V _{IH}	(i,o)	Input High Voltage	HI_REF + 0.15			V	
V _{OL}	(i,o)	Output Low Voltage			0.1 x VCC1_8	V	I _{OL} = 1 mA
V _{OH}	(i,o)	Output High Voltage	0.9 x VCC1_8			V	I _{OH} = 1 mA
I _{OL}	(i,o)	Output Low Current			1	mA	@V _{OL,HI} max
I _{OH}	(i,o)	Output High Current	-1			mA	@V _{OH,HI} max
I _{LEAK}	(i,o)	Input Leakage Current			-150, +15	µA	0<V _{in} <VCC1_8
C _{IN}	(i,o)	Input Capacitance	2.58		3.17	pF	
Clock Signals							
V _{IL}	(v)	Input Low Voltage			0.8	V	
V _{IH}	(v)	Input High Voltage	2.4			V	
C _{IN}	(v)	Input Capacitance	1.2		1.4	pF	
V _{IL}	(w)	Input Low Voltage		0		V	
V _{IH}	(w)	Input High Voltage	0.660	0.710	0.850	V	
V _{CROSS}	(w)	Crossing Voltage	0.45 x (V _{IH} – V _{IL})	0.5 x (V _{IH} – V _{IL})	0.55 x (V _{IH} – V _{IL})	V	
C _{IN}	(w)	Input Capacitance	0.94		1.1	pF	
RSTIN# Signals							
V _{IL}	(p)	Input Low Voltage			0.8	V	
V _{IH}	(p)	Input High Voltage	2.0			V	
I _{LEAK}	(p)	Input Leakage Current			±100	µA	0<V _{in} <VCC3_3



This page is intentionally left blank.

7 *Ballout and Package Information*

This chapter provides the MCH ballout and package information. The ballout footprint is shown in Figure 6 and Figure 7. These figures represent the ballout organized by ball number. Table 22 provides the MCH ballout listed alphabetically by signal name.

The following notes apply to the ballout.

Note: NC = No Connect.

Note: RSVD = These pins should not be connected and should be allowed to float.

Note: VSS = Connect to ground.



Figure 6. Intel® 82845 MCH Ballout Diagram (Top View—Left Side)

	29	28	27	26	25	24	23	22	21	20	19	18	17	16	15
AJ			VSS		VCC1_5		VTT		VTT		VTT		VSS		VSS
AH		SBA0	SBA1		G_GNT#		VSS		VSS		VSS		HD61#		HD57#
AG	VCC1_5	SBA2	SBA3	ST2	ST0	G_REQ#	VTT	VSS	VTT	VSS	VTT	VSS	HD56#	HD55#	HD54#
AF			SB_STB	SB_STB#	VSS	ST1	VCC1_5	PIPE#	VSS	VTT	VSS	VTT	VSS	HD59#	VSS
AE	VSS	SBA4	SBA5	VCC1_5	SBA7	SBA6	WBF#	RBF#	VTT	VSS	VTT	VSS	CPURST#	HD63#	HD60#
AD			NC	NC	GRCOMP	G_AD31	VCC1_5	VSS	VCC1_5	VTT	VSS	VTT	HD62#	VSS	DBI3#
AC	VCC1_5	AD_STB1#	AD_STB1	VSS	G_AD28	G_AD29	VSS	G_AD30	VSS	VSS	VTT	VSS	HD58#	HDSTBP3#	HDSTBN3#
AB			G_AD20	G_AD22	G_AD19	G_AD27	G_AD24	VSS	VCC1_5	VTT	VSS	VTT	HVREF	VSS	VSS
AA	VSS	G_AD18	G_AD21	VCC1_5	G_AD26	G_AD25	G_C/BE3#	VCC1_5	AGPREF						
Y			G_AD16	G_AD17	G_C/BE2#	G_FRAME#	G_AD23	VSS							
W	VCC1_5	G_DEVSEL#	G_JRDY#	VSS	G_PAR	G_TRDY#	G_STOP#	VCC1_5							
V			G_AD9	G_AD8	G_C/BE0#	G_AD15	G_C/BE1#	VSS							
U	VSS	G_AD7	G_AD6	VCC1_5	G_AD14	G_AD13	G_AD11	VCC1_5							
T			G_AD5	G_AD4	G_AD2	G_AD12	G_AD10	VSS							
R	VCC1_5	G_AD1	G_AD0	VSS	G_AD3	AD_STB0	AD_STB0#	VCC1_5							
P			HLRCOMP	HI_REF	HI_0	HI_1	HI_3	66IN							
N	VSS	HI_9	HI_2	VCC1_8	HI_STB	HI_STB#	VCC1_8	VSS							
M			HI_8	HI_4	HI_5	HI_10	VSS	VCC1_8							
L	VCC1_8	HI_6	HI_7	VSS	VCC1_8	VSS	VCCSM	VSS							
K			VSS	VCCSM	RSVD	VCCSM	RSVD	VCCSM							
J	VSS	SMRCOMP	RSTIN#	VSS	SCAS#	SCS4#	SCS1#	VSS	SDREF						
H			RSVD	TESTIN#	SCS9#	VCCSM	SCS0#	VCCSM	VSS	VCCSM	VSS	VCCSM	VSS	VCCSM	VSS
G	VCCSM	SDQ32	SWE#	VSS	SCS8#	SCS5#	SRAS#	SMA0	SMA3	SMA5	SMA8	SMA9	SBS1	SCK8	SCK4
F			SDQ0	RSVD	SDQ37	VSS	SDQ8	VCCSM	SMA2	VSS	SMA7	VCCSM	SBS0	VSS	SCK9
E	VSS	SDQ33	SDQ1	VSS	SDQ5	SDQ39	SDQ41	SDQ43	SMA1	SMA4	SMA6	SDQ47	SMA10	SCB1	SMA11
D			SDQ35	SDQ4	VCCSM	SDQ7	VCCSM	SDQ42	VSS	SDQ12	VCCSM	SDQ46	VSS	SCB5	VCCSM
C	VCCSM	SDQ34	SDQ3	RSVD	SDQ38	SDQ40	RSVD	SDQ10	SDQ11	SDQ45	SDQ13	SDQ14	SDQ15	SCB0	SCB2
B		SDQ2	SDQ36		SDQ6		SDQ9		SDQ44		RSVD		SCB4		SCB6
A			VSS		VCCSM		VSS		VCCSM		VSS		VCCSM		VSS

VSSA1	VCC1_5	VSS
VCCA1	VSS	VCC1_5
VSS	VCC1_5	VSS
VCC1_5	VSS	VCC1_5
VSS	VCC1_5	VSS

NOTES:

1. NC = No Connect.
2. RSVD = These pins should not be connected and should be allowed to float.
3. VSS = Connect to ground.

Figure 7. Intel® 82845 MCH Ballout Diagram (Top View—Right Side)

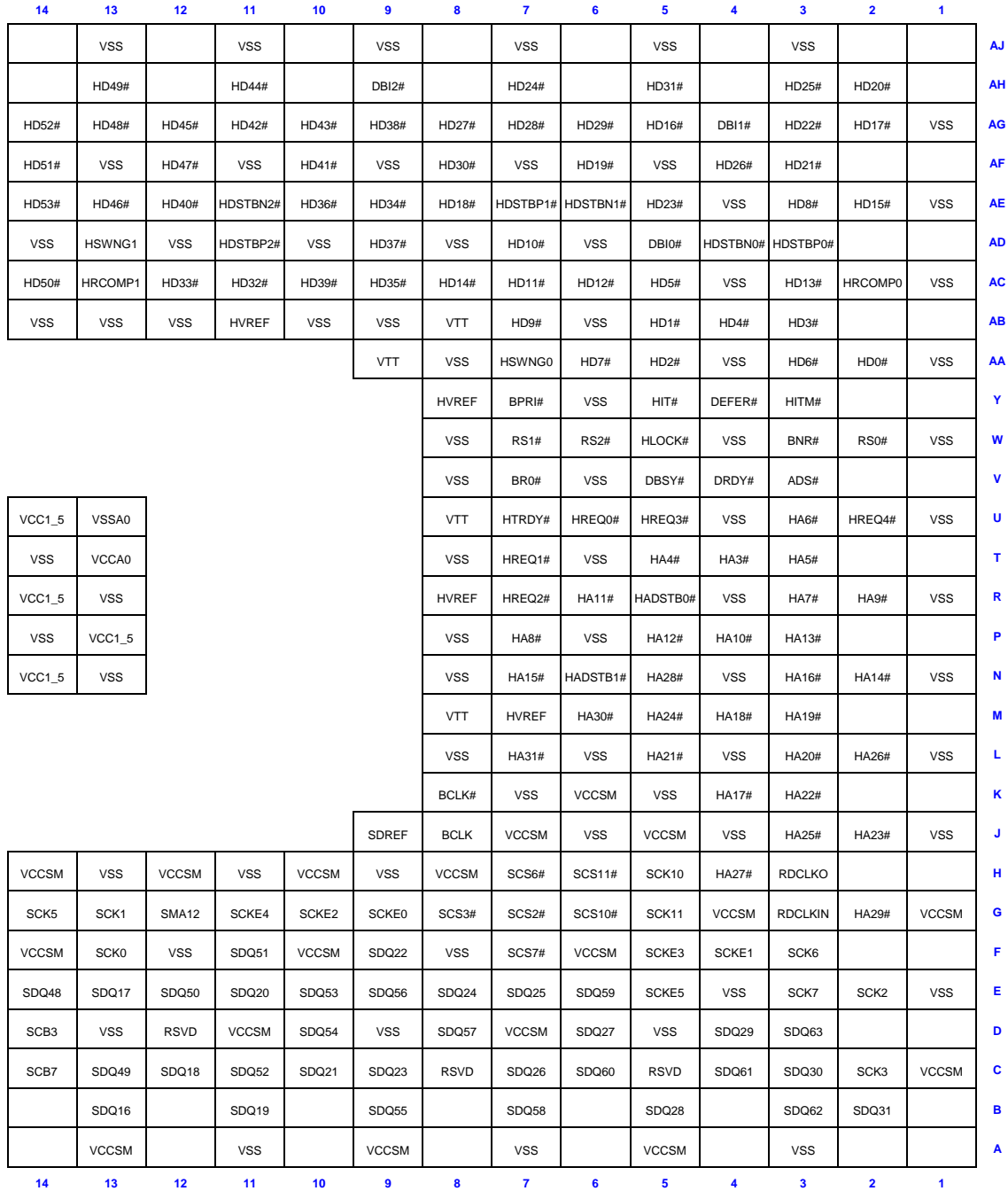

NOTES:

1. NC = No Connect.
2. RSVD = These pins should not be connected and should be allowed to float.
3. VSS = Connect to ground.

Table 22. Intel® 82845 MCH Ballout Listed Alphabetically by Signal Name

Signal Name	Ball #
66IN	P22
AD_STB0	R24
AD_STB0#	R23
AD_STB1	AC27
AD_STB1#	AC28
ADS#	V3
AGPREF	AA21
BCLK#	K8
BCLK	J8
BNR#	W3
BPRI#	Y7
BR0#	V7
CPURST#	AE17
DBSY#	V5
DEFER#	Y4
DBI0#	AD5
DBI1#	AG4
DBI2#	AH9
DBI3#	AD15
DRDY#	V4
G_AD0	R27
G_AD1	R28
G_AD2	T25
G_AD3	R25
G_AD4	T26
G_AD5	T27
G_AD6	U27
G_AD7	U28
G_AD8	V26
G_AD9	V27
G_AD10	T23
G_AD11	U23
G_AD12	T24
G_AD13	U24

Signal Name	Ball #
G_AD14	U25
G_AD15	V24
G_AD16	Y27
G_AD17	Y26
G_AD18	AA28
G_AD19	AB25
G_AD20	AB27
G_AD21	AA27
G_AD22	AB26
G_AD23	Y23
G_AD24	AB23
G_AD25	AA24
G_AD26	AA25
G_AD27	AB24
G_AD28	AC25
G_AD29	AC24
G_AD30	AC22
G_AD31	AD24
G_C/BE0#	V25
G_C/BE1#	V23
G_C/BE2#	Y25
G_C/BE3#	AA23
G_DEVSEL#	W28
G_FRAME#	Y24
G_GNT#	AH25
G_IRDY#	W27
G_PAR	W25
G_REQ#	AG24
G_STOP#	W23
G_TRDY#	W24
GRCOMP	AD25
HA3#	T4
HA4#	T5
HA5#	T3



Signal Name	Ball #
HA6#	U3
HA7#	R3
HA8#	P7
HA9#	R2
HA10#	P4
HA11#	R6
HA12#	P5
HA13#	P3
HA14#	N2
HA15#	N7
HA16#	N3
HA17#	K4
HA18#	M4
HA19#	M3
HA20#	L3
HA21#	L5
HA22#	K3
HA23#	J2
HA24#	M5
HA25#	J3
HA26#	L2
HA27#	H4
HA28#	N5
HA29#	G2
HA30#	M6
HA31#	L7
HADSTB0#	R5
HADSTB1#	N6
HD0#	AA2
HD1#	AB5
HD2#	AA5
HD3#	AB3
HD4#	AB4
HD5#	AC5
HD6#	AA3
HD7#	AA6

Signal Name	Ball #
HD8#	AE3
HD9#	AB7
HD10#	AD7
HD11#	AC7
HD12#	AC6
HD13#	AC3
HD14#	AC8
HD15#	AE2
HD16#	AG5
HD17#	AG2
HD18#	AE8
HD19#	AF6
HD20#	AH2
HD21#	AF3
HD22#	AG3
HD23#	AE5
HD24#	AH7
HD25#	AH3
HD26#	AF4
HD27#	AG8
HD28#	AG7
HD29#	AG6
HD30#	AF8
HD31#	AH5
HD32#	AC11
HD33#	AC12
HD34#	AE9
HD35#	AC9
HD36#	AE10
HD37#	AD9
HD38#	AG9
HD39#	AC10
HD40#	AE12
HD41#	AF10
HD42#	AG11
HD43#	AG10



Signal Name	Ball #
HD44#	AH11
HD45#	AG12
HD46#	AE13
HD47#	AF12
HD48#	AG13
HD49#	AH13
HD50#	AC14
HD51#	AF14
HD52#	AG14
HD53#	AE14
HD54#	AG15
HD55#	AG16
HD56#	AG17
HD57#	AH15
HD58#	AC17
HD59#	AF16
HD60#	AE15
HD61#	AH17
HD62#	AD17
HD63#	AE16
HDSTBN0#	AD4
HDSTBP0#	AD3
HDSTBN1#	AE6
HDSTBP1#	AE7
HDSTBN2#	AE11
HDSTBP2#	AD11
HDSTBN3#	AC15
HDSTBP3#	AC16
HI_0	P25
HI_1	P24
HI_2	N27
HI_3	P23
HI_4	M26
HI_5	M25
HI_6	L28
HI_7	L27

Signal Name	Ball #
HI_8	M27
HI_9	N28
HI_10	M24
HI_REF	P26
HI_STB	N25
HI_STB#	N24
HIT#	Y5
HITM#	Y3
HLOCK#	W5
HLRCOMP	P27
HRCOMP0	AC2
HRCOMP1	AC13
HREQ0#	U6
HREQ1#	T7
HREQ2#	R7
HREQ3#	U5
HREQ4#	U2
HSWNG0	AA7
HSWNG1	AD13
HTRDY#	U7
HVREF	M7, R8, Y8, AB11, AB17
NC	AD26, AD27
PIPE#	AF22
RBF#	AE22
RDCLKIN	G3
RDCLKO	H3
RS0#	W2
RS1#	W7
RS2#	W6
RSTIN#	J27
RSVD	B19, C5, C8, C23, C26, D12, F26, H27, K23, K25
SBA0	AH28
SBA1	AH27
SBA2	AG28
SBA3	AG27



Signal Name	Ball #
SBA4	AE28
SBA5	AE27
SBA6	AE24
SBA7	AE25
SB_STB	AF27
SB_STB#	AF26
SBS0	F17
SBS1	G17
SCAS#	J25
SCK0	F13
SCK1	G13
SCK2	E2
SCK3	C2
SCK4	G15
SCK5	G14
SCK6	F3
SCK7	E3
SCK8	G16
SCK9	F15
SCK10	H5
SCK11	G5
SCKE0	G9
SCKE1	F4
SCKE2	G10
SCKE3	F5
SCKE4	G11
SCKE5	E5
SCS0#	H23
SCS1#	J23
SCS2#	G7
SCS3#	G8
SCS4#	J24
SCS5#	G24
SCS6#	H7
SCS7#	F7
SCS8#	G25

Signal Name	Ball #
SCS9#	H25
SCS10#	G6
SCS11#	H6
SDQ0	F27
SDQ1	E27
SDQ2	B28
SDQ3	C27
SDQ4	D26
SDQ5	E25
SDQ6	B25
SDQ7	D24
SDQ8	F23
SDQ9	B23
SDQ10	C22
SDQ11	C21
SDQ12	D20
SDQ13	C19
SDQ14	C18
SDQ15	C17
SDQ16	B13
SDQ17	E13
SDQ18	C12
SDQ19	B11
SDQ20	E11
SDQ21	C10
SDQ22	F9
SDQ23	C9
SDQ24	E8
SDQ25	E7
SDQ26	C7
SDQ27	D6
SDQ28	B5
SDQ29	D4
SDQ30	C3
SDQ31	B2
SDQ32	G28



Signal Name	Ball #
SDQ33	E28
SDQ34	C28
SDQ35	D27
SDQ36	B27
SDQ37	F25
SDQ38	C25
SDQ39	E24
SDQ40	C24
SDQ41	E23
SDQ42	D22
SDQ43	E22
SDQ44	B21
SDQ45	C20
SDQ46	D18
SDQ47	E18
SDQ48	E14
SDQ49	C13
SDQ50	E12
SDQ51	F11
SDQ52	C11
SDQ53	E10
SDQ54	D10
SDQ55	B9
SDQ56	E9
SDQ57	D8
SDQ58	B7
SDQ59	E6
SDQ60	C6
SDQ61	C4
SDQ62	B3
SDQ63	D3
SCB0	C16
SCB1	E16
SCB2	C15
SCB3	D14
SCB4	B17

Signal Name	Ball #
SCB5	D16
SCB6	B15
SCB7	C14
SDREF	J9, J21
SMA0	G22
SMA1	E21
SMA2	F21
SMA3	G21
SMA4	E20
SMA5	G20
SMA6	E19
SMA7	F19
SMA8	G19
SMA9	G18
SMA10	E17
SMA11	E15
SMA12	G12
SMRCOMP	J28
SRAS#	G23
ST0	AG25
ST1	AF24
ST2	AG26
SWE#	G27
TESTIN#	H26
VCC1_5	R22, R29, U22, U26, W22, W29, AA22, AA26, AB21, AC29, AD21, AD23, AE26, AF23, AG29, AJ25
VCC1_5	N14, N16, P13, P15, P17, R14, R16, T15, U14, U16
VCCA1	T17
VCCA0	T13
VCC1_8	L25, L29, M22, N23, N26
VCCSM	A5, A9, A13, A17, A21, A25, C1, C29, D7, D11, D15, D19, D23, D25, F6, F10, F14, F18, F22, G1, G4, G29, H8, H10, H12, H14, H16, H18, H20, H22, H24, J5, J7, K6, K22, K24, K26, L23

Signal Name	Ball #
VSS	A3, A7, A11, A15, A19, A23, A27, D5, D9, D13, D17, D21, E1, E4, E26, E29, F8, F12, F16, F20, F24, G26, H9, H11, H13, H15, H17, H19, H21, J1, J4, J6, J22, J26, J29, K5, K7, K27, L1, L4, L6, L8, L22, L24, L26, M23, N1, N4, N8, N13, N15, N17, N22, N29, P6, P8, P14, P16, R1, R4, R13, R15, R17, R26, T6, T8, T14, T16, T22, U1, U4, U15, U29, V6, V8, V22, W1, W4, W8, W26, Y6, Y22, AA1, AA4, AA8, AA29, AB6, AB9, AB10, AB12, AB13, AB14, AB15, AB16, AB19, AB22, AC1, AC4, AC18, AC20, AC21, AC23, AC26, AD6, AD8, AD10, AD12, AD14, AD16, AD19, AD22, AE1, AE4, AE18, AE20, AE29, AF5, AF7, AF9, AF11, AF13, AF15, AF17, AF19, AF21, AF25, AG1, AG18, AG20, AG22, AH19, AH21, AH23, AJ3, AJ5, AJ7, AJ9, AJ11, AJ13, AJ15, AJ17, AJ27

Signal Name	Ball #
VSSA1	U17
VSSA0	U13
VTT	M8, U8, AA9, AB8, AB18, AB20, AC19, AD18, AD20, AE19, AE21, AF18, AF20, AG19, AG21, AG23, AJ19, AJ21, AJ23
WBF#	AE23

NOTES:

1. NC = No Connect.
2. RSVD = These pins should not be connected and should be allowed float.
3. VSS = Connect to ground.

7.1 Package Mechanical Information

This section provides the MCH package mechanical dimensions. The package is a 593 ball FC-BGA.

Figure 8. Intel® MCH FC-BGA Package Dimensions (Top and Side View)

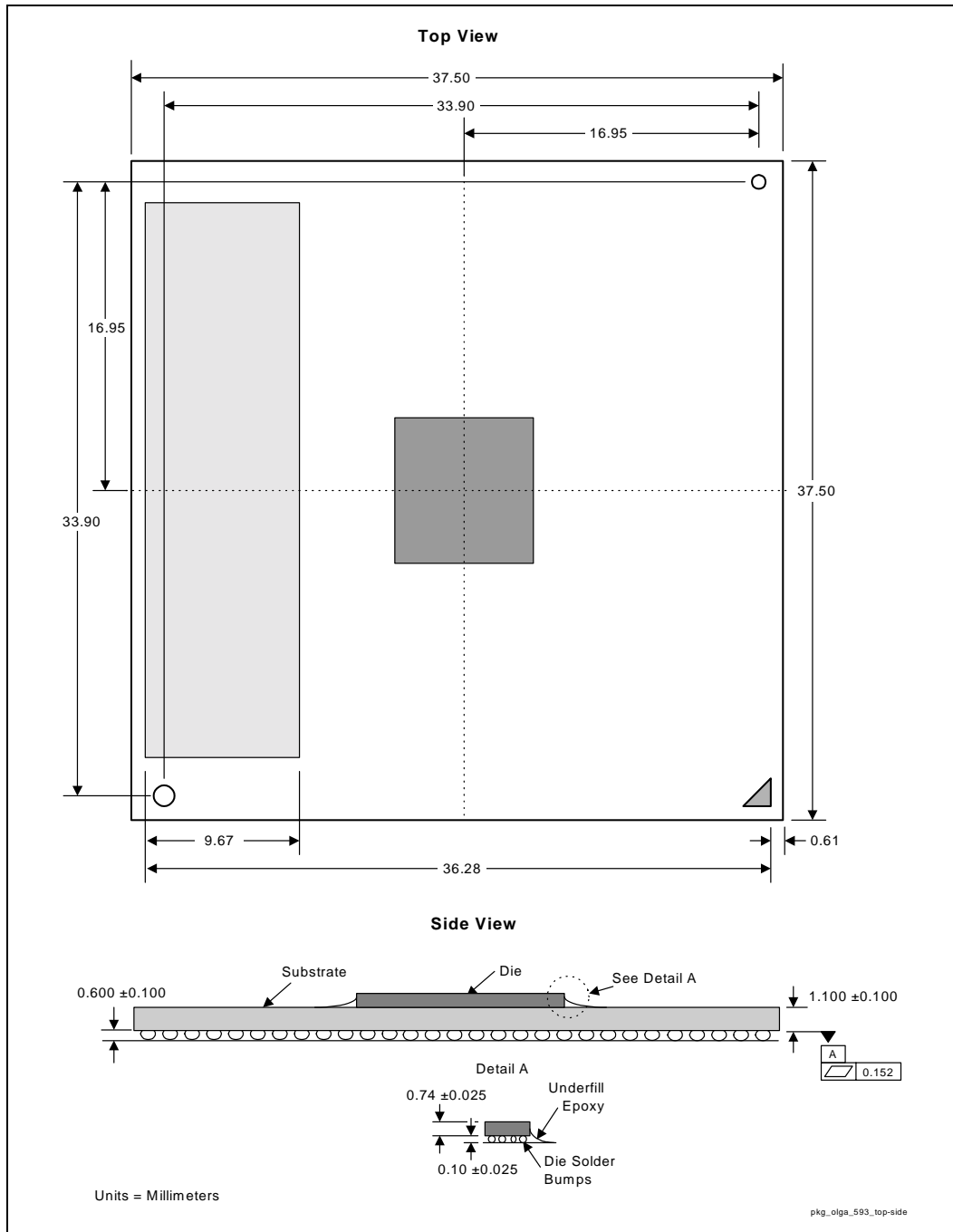
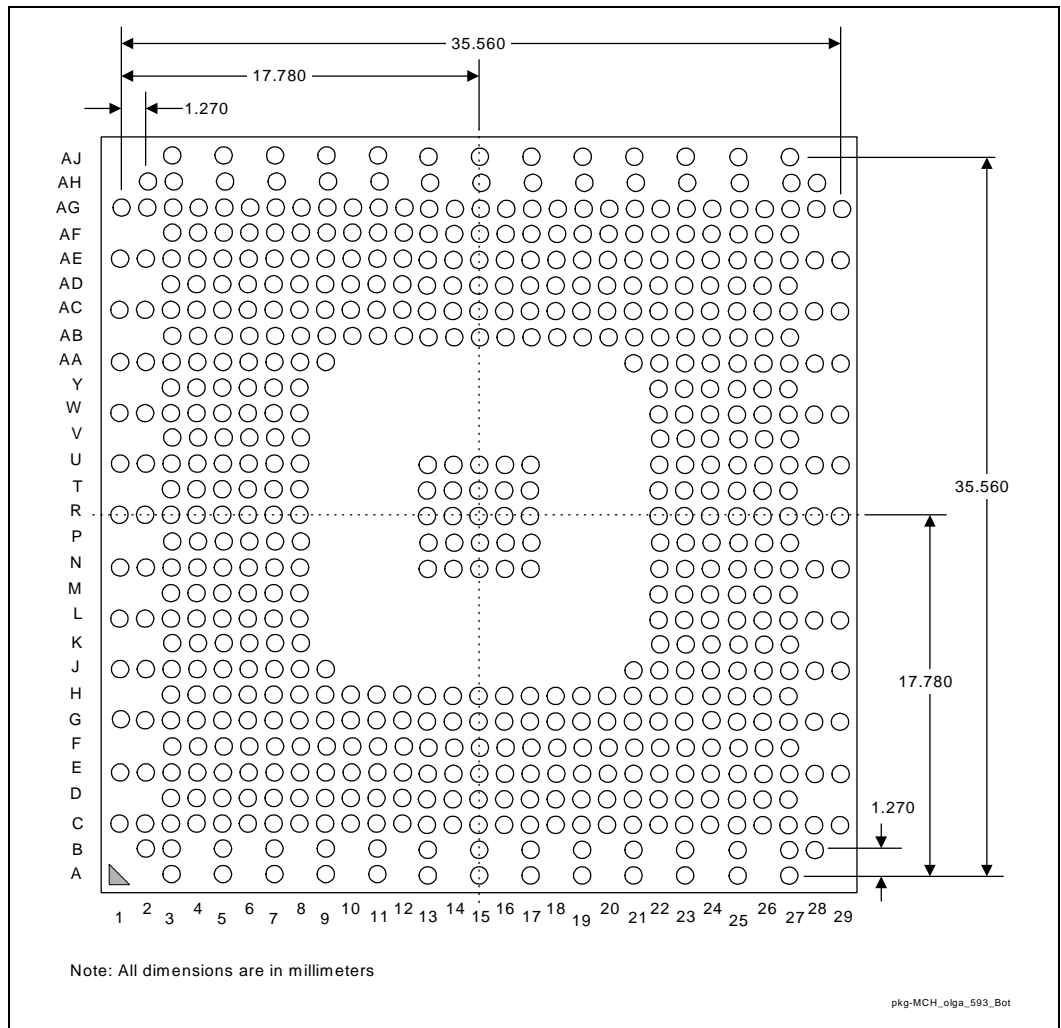

Figure 9. Intel® MCH FC-BGA Package Dimensions (Bottom View)





This page is intentionally left blank.

8 Testability

In the MCH, testability for Automated Test Equipment (ATE) board-level testing has been implemented as an XOR chain. An XOR-tree is a chain of XOR gates, each with one input pin connected to it (see Figure 10).

Figure 10. XOR Tree Chain

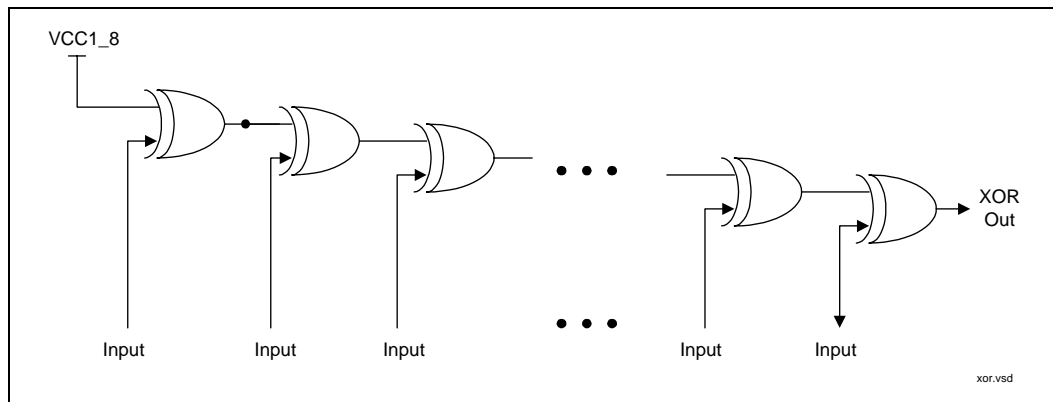

The algorithm used for in-circuit test is as follows:

- Drive all input pins to an initial logic level 1. Observe the output corresponding to scan chain being tested.
- Toggle pins one at a time (starting from the first pin in the chain and continuing to the last pin) from its initial logic level to the opposite logic level. Observe the output changes with each pin toggle.

8.1 XOR Test Mode Initialization

XOR test mode can be entered by pulling three shared pins (reset straps) low through the rising transition of RSTIN#. The signals that need to be pulled are as follows:

- G_GNT# = 0 (Global strap enable)
- SBA1 = 0 (XOR strap)
- ST2 = 0 (PLL Bypass mode; it is recommended to enter PLL Bypass in XOR test mode)

8.2 XOR Chains

Note: RSTIN#, TESTIN#, and all Rcomp buffers are not part of any XOR chain.

Table 23. XOR Chain 0

Chain 0 Ball	Element #	Signal Name	Note	Initial Logic Level
AE6	1	HDSTBP1#	Input	1
AD3	2	HDSTBP0#	Input	1
V3	3	ADS#	Input	1
U6	4	HREQ0#	Input	1
U3	5	HA6#	Input	1
U2	6	HREQ4#	Input	1
U5	7	HREQ3#	Input	1
T5	8	HA4#	Input	1
T7	9	HREQ1#	Input	1
T4	10	HA3#	Input	1
R7	11	HREQ2#	Input	1
R5	12	HADSTB0#	Input	1
R3	13	HA7#	Input	1
P3	14	HA13#	Input	1
R2	15	HA9#	Input	1
R6	16	HA11#	Input	1
T3	17	HA5#	Input	1
N3	18	HA16#	Input	1
P5	19	HA12#	Input	1
P4	20	HA10#	Input	1
P7	21	HA8#	Input	1
N2	23	HA14#	Input	1
N7	24	HA15#	Input	1
N5	25	HA28#	Input	1
M4	26	HA18#	Input	1
L3	27	HA20#	Input	1
M3	28	HA19#	Input	1
L2	29	HA26#	Input	1
K3	30	HA22#	Input	1

Chain 0 Ball	Element #	Signal Name	Note	Initial Logic Level
M5	31	HA24#	Input	1
K3	32	HA23#	Input	1
K4	33	HA17#	Input	1
J3	34	HA25#	Input	1
L5	35	HA21#	Input	1
H4	36	HA27#	Input	1
M6	37	HA30#	Input	1
L7	38	HA31#	Input	1
G2	39	HA29#	Input	1
H6	40	SCS11#	Input	1
H3	41	RDCLKIN	Input	1
G3	42	RDCLKO	Input	1
H5	43	SCK10	Input	1
G6	44	SCS10#	Input	1
E7	45	SCS7#	Input	1
G8	46	SCS3#	Input	1
G9	47	SCKE0	Input	1
AH28	48	SBA0	Output	N/A

Table 24. XOR Chain 1

Chain 1 Ball	Element #	Signal Name	Note	Initial Logic Level
N6	1	HADSTDB1#	Input	1
H7	2	SCS6#	Input	1
G10	3	SCKE2	Input	1
G5	4	SCK11	Input	1
F4	5	SCKE1	Input	1
F3	6	SCK6	Input	1
C2	7	SCK3	Input	1
B2	8	SDQ31	Input	1
E2	9	SCK2	Input	1
D3	10	SDQ63	Input	1
E3	11	SCK7	Input	1
G7	12	SCS2#	Input	1
C3	13	SDQ30	Input	1
E5	14	SCKE5	Input	1
F7	15	SCS7#	Input	1
D4	16	SDQ29	Input	1
C4	17	SDQ61	Input	1
C5	18	RSVD	Input	1
E6	19	SDQ59	Input	1
D6	20	SDQ27	Input	1
B3	21	SDQ62	Input	1
C6	22	SDQ60	Input	1
B5	23	SDQ28	Input	1
C7	24	SDQ26	Input	1
B7	25	SDQ58	Input	1
E8	26	SDQ24	Input	1
C8	27	RSVD	Input	1
C9	28	SDQ23	Input	1
D8	29	SDQ57	Input	1
E10	30	SDQ53	Input	1
B9	31	SDQ5	Input	1
E11	32	SDQ20	Input	1
E9	33	SDQ56	Input	1
AH27	34	SBA1	Output	N/A

Table 25. XOR Chain 2

Chain 2 Ball	Element #	Signal Name	Note	Initial Logic Level
D10	1	SDQ54	Input	1
C10	2	SDQ21	Input	1
C11	3	SDQ52	Input	1
F9	4	SDQ22	Input	1
B11	5	SDQ19	Input	1
B13	6	SDQ16	Input	1
G11	7	SCKE4	Input	1
C12	8	SDQ18	Input	1
F11	9	SDQ51	Input	1
C13	10	SDQ49	Input	1
D12	11	RSVD	Input	1
E12	12	SDQ50	Input	1
E13	13	SDQ17	Input	1
G14	14	SCK5	Input	1
G13	15	SCK1	Input	1
F15	16	SCK9	Input	1
E15	17	SMA11	Input	1
G16	18	SCK8	Input	1
E16	19	SDQ65	Input	1
E18	20	SDQ47	Input	1
F17	21	SBS0	Input	1
F19	22	SMA7	Input	1
G18	23	SMA9	Input	1
G20	24	SMA5	Input	1
G19	25	SMA8	Input	1
F21	26	SMA2	Input	1
G21	27	SMA3	Input	1
E22	28	SDQ43	Input	1
G24	29	SCS5#	Input	1
G23	30	SRAS#	Input	1
G25	31	SCS8#	Input	1
H23	32	SCS0#	Input	1
J25	33	SCAS#	Input	1
AG28	34	SBA2	Output	N/A

Table 26. XOR Chain 3

Chain 3 Ball	Element #	Signal Name	Note	Initial Logic Level
G10	1	SCKE0	Input	1
G12	2	SMA12	Input	1
G15	3	SCK4	Input	1
F13	4	SCK0	Input	1
C14	5	SCB3	Input	1
E14	6	SDQ48	Input	1
D14	7	SCB7	Input	1
C15	8	SCB6	Input	1
G17	9	SBCS1	Input	1
C16	10	SDQ64	Input	1
D16	11	SCB5	Input	1
B15	12	SCB5	Input	1
C17	13	SDQ15	Input	1
B17	14	SCB4	Input	1
D18	15	SDQ46	Input	1
E17	16	SMA10	Input	1
B19	17	RSVD	Input	1
C18	18	SDQ14	Input	1
E19	19	SMA6	Input	1
C19	20	SDQ13	Input	1
C20	21	SDQ45	Input	1
D20	22	SDQ12	Input	1
C21	23	SDQ11	Input	1
E20	24	SMA4	Input	1
B21	25	SDQ44	Input	1
E21	26	SMA1	Input	1
C22	27	SDQ10	Input	1
D22	28	SDQ42	Input	1
C24	29	SDQ40	Input	1
C23	30	RSVD	Input	1
B23	31	SDQ9	Input	1
D24	32	SDQ7	Input	1
G22	33	SMA0	Input	1
E23	34	SDQ41	Input	1

Chain 3 Ball	Element #	Signal Name	Note	Initial Logic Level
B25	35	SDQ6	Input	1
C25	36	SDQ38	Input	1
C27	37	SDQ3	Input	1
D27	38	SDQ35	Input	1
B27	39	SDQ36	Input	1
C26	40	RSVD	Input	1
F23	41	SDQ8	Input	1
E24	42	SDQ39	Input	1
E25	43	SDQ5	Input	1
E27	44	SDQ1	Input	1
N24	45	HI_STB#	Input	1
R24	46	AD_STB	Input	1
AG27	47	SBA3	Output	N/A

Table 27. XOR Chain 4

Chain 4 Ball	Element #	Signal Name	Note	Initial Logic Level
D26	1	SDQ4	Input	1
F25	2	SDQ37	Input	1
B28	3	SDQ2	Input	1
C28	4	SDQ3	Input	1
E28	5	SDQ33	Input	1
J24	6	SCS4#	Input	1
F26	7	RSVD	Input	1
H25	8	SCS9#	Input	1
K25	9	RSVD	Input	1
J23	10	SCS1#	Input	1
F27	11	SDQ0	Input	1
K23	12	RSVD	Input	1
G28	13	SDQ32	Input	1
G27	14	SWE#	Input	1
M27	15	HI_8	Input	1
M24	16	HI_10	Input	1
N28	17	HI_9	Input	1
L28	18	HI_6	Input	1
M25	19	HI_5	Input	1

Chain 4 Ball	Element #	Signal Name	Note	Initial Logic Level
N27	20	HI_2	Input	1
M26	21	HI_4	Input	1
N25	22	HI_STB	Input	1
L27	23	HI_7	Input	1
P25	24	HI_0	Input	1
P23	25	HI_3	Input	1
P24	26	HI_1	Input	1
R27	27	G_ADO	Input	1
R28	28	G_AD1	Input	1
U27	29	G_AD6	Input	1
R25	30	G_AD3	Input	1
T27	31	G_AD5	Input	1
T36	32	G_AD4	Input	1
U28	33	G_AD7	Input	1
R24	34	AD_STB0	Input	1
V27	35	G_AD9	Input	1
T25	36	G_AD2	Input	1
U27	37	G_AD8	Input	1
T24	38	G_AD12	Input	1
U24	39	G_AD13	Input	1
U25	40	G_AD14	Input	1
T23	41	G_AD10	Input	1
V24	42	G_AD15	Input	1
U23	43	G_AD11	Input	1
AE28	44	SBA4	Output	N/A

Table 28. XOR Chain 5

Chain 5 Ball	Element #	Signal Name	Note	Initial Logic Level
V25	1	G_C/BE0#	Input	1
W28	2	G_DEVSEL#	Input	1
W25	3	G_PAR	Input	1
Y25	4	G_C/BE2#	Input	1
W27	5	G_IRDY#	Input	1
V23	6	G_C/BE1#	Input	1
Y24	7	G_FRAME#	Input	1

Chain 5 Ball	Element #	Signal Name	Note	Initial Logic Level
W24	8	G_TRDY#	Input	1
AE23	9	WBF#	Input	1
W23	10	G_STOP#	Input	1
AA23	11	G_C/BE3#	Input	1
AA28	12	G_AD18	Input	1
Y26	13	G_AD17	Input	1
Y27	14	G_AD16	Input	1
AB27	15	G_AD20	Input	1
AB26	16	G_AD22	Input	1
AA25	17	G_AD26	Input	1
AA24	18	G_AD25	Input	1
AA27	19	G_AD21	Input	1
AC27	20	AD_STB1	Input	1
Y23	21	G_AD23	Input	1
AC25	22	G_AD28	Input	1
AB25	23	G_AD19	Input	1
AB23	24	G_AD24	Input	1
AB24	25	G_AD31	Input	1
AC24	26	G_AD29	Input	1
AC22	27	G_AD30	Input	1
AB24	28	G_AD27	Input	1
AE22	29	RBF#	Input	1
AF24	30	ST1	Input	1
AF22	31	PIPE#	Input	1
AF27	32	SB_STB	Input	1
AH25	33	G_GNT#	Input	1
AG25	34	ST0	Input	1
AG24	35	G_REQ#	Input	1
AG26	36	ST2	Input	1
AH17	37	HD61#	Input	1
AG16	38	HD55#	Input	1
AG17	39	HD56#	Input	1
AC16	40	HDSTBP3#	Input	1
AE11	41	HDSTBP2#	Input	1
AE27	42	SBA5	Output	N/A

Table 29. XOR Chain 6

Chain 6 Ball	Element #	Signal Name	Note	Initial Logic Level
AC27	1	AD_STB1	Input	1
AF27	2	SB_STB	Input	1
AE17	3	CPURST#	Input	1
AD17	4	HD62#	Input	1
AE16	5	HD63#	Input	1
AH15	6	HD57#	Input	1
AG15	7	HD54#	Input	1
AF16	8	HD59#	Input	1
AC16	9	HDSTBP3#	Input	1
AE15	10	HD60#	Input	1
AG14	11	HD52#	Input	1
AC17	12	HD58#	Input	1
AF14	13	HD51#	Input	1
AE14	14	HD53#	Input	1
AH13	15	HD49#	Input	1
AD15	16	DBI3#	Input	1
AG13	17	HD48#	Input	1
AC14	18	HD50#	Input	1
AF12	19	HD47#	Input	1
AG12	20	HD45#	Input	1
AE12	21	HD40#	Input	1
AE13	22	HD46#	Input	1
AH9	23	DBI2#	Input	1
AG10	24	HD43#	Input	1
AH11	25	HD44#	Input	1
AG9	26	HD38#	Input	1
AG11	27	HD42#	Input	1
AE11	28	HDSTBN2#	Input	1
AF10	29	HD41#	Input	1
AE10	30	HD36#	Input	1
AC12	31	HD33#	Input	1
AC11	32	HD32#	Input	1
AC10	33	HD39#	Input	1
AE9	34	HD34#	Input	1

Chain 6 Ball	Element #	Signal Name	Note	Initial Logic Level
AC9	35	HD35#	Input	1
AD9	36	HD37#	Input	1
AH7	37	HD24#	Input	1
AH5	38	HD31#	Input	1
AG8	39	HD27#	Input	1
Y4	40	DEFER#	Input	1
W7	41	RS1#	Input	1
AE24	42	SBA6	Output	N/A

Table 30. XOR Chain 7

Chain 7 Ball	Element #	SDR Ball name	Note	Initial Logic Level
AG6	1	HD29#	Input	1
AG5	2	HD16#	Input	1
AG7	3	HD28#	Input	1
AF6	4	HD19#	Input	1
AF8	5	HD30#	Input	1
AE6	6	HDSTBN1#	Input	1
AG4	7	DBI1#	Input	1
AH3	8	HD25#	Input	1
AE8	9	HD18#	Input	1
AG2	10	HD17#	Input	1
AF4	11	HD26#	Input	1
AH2	12	HD20#	Input	1
AE5	13	HD23#	Input	1
AG3	14	HD22#	Input	1
AF3	15	HD21#	Input	1
AD7	16	HD10#	Input	1
AC7	17	HD11#	Input	1
AC8	18	HD14#	Input	1
AD5	19	DBI0#	Input	1
AC6	20	HD12#	Input	1
AE2	21	HD15#	Input	1
AB7	22	HD9#	Input	1
AE3	23	HD8#	Input	1
AD4	24	HDSTBN0#	Input	1

Chain 7 Ball	Element #	SDR Ball name	Note	Initial Logic Level
AC3	25	HD13#	Input	1
AB5	26	HD1#	Input	1
AC5	27	HD5#	Input	1
AA6	28	HD7#	Input	1
AA5	29	HD2#	Input	1
AB3	30	HD3#	Input	1
AA3	31	HD6#	Input	1
AB4	32	HD4#	Input	1
AA2	33	HD0#	Input	1
Y5	34	HIT#	Input	1
Y7	35	BPRI#	Input	1
W6	36	RS2#	Input	1
Y3	37	HITM#	Input	1
U7	38	HTRDY#	Input	1
W5	39	HLOCK#	Input	1
V7	40	BR0#	Input	1
W3	41	BNR#	Input	1
W2	41	RS0#	Input	1
V5	43	DBSY#	Input	1
V4	44	DRDY#	Input	1
AE25	45	SBA7	Output	N/A